



**AUSTRALIAN NATIONAL KENNEL COUNCIL**

**FLYBALL RULES**

**Rules for the conduct of Flyball Competitions**

**(Effective from 1<sup>st</sup> January 2008)**

**Rules reproduced under the Agreement between the  
Australian National Kennel Council and the Australian Flyball Association Inc.**

## TABLE OF CONTENTS

### **CHAPTER 1 – CONDUCTING A SANCTIONED COMPETITION** **1**

- Section 1.1 – Requirements
- Section 1.2 – Points
- Section 1.3 – Format and Schedule
- Section 1.4 – Seed Times and Break Out Penalties
- Section 1.5 – Meaningless Heats

### **CHAPTER 2 – RULES FOR COMPETITION**

- Section 2.1 – Code of Ethics
- Section 2.2 – Misconduct
- Section 2.3 – Amateur Competition
- Section 2.4 – Changes Teams
- Section 2.5 – Protest
- Section 2.6 – Signal Cards
- Section 2.7 – Record Times

### **CHAPTER 3 – EQUIPMENT**

- Section 3.1 – Flyball Boxes
- Section 3.2 – Balls
- Section 3.3 – Jumps

### **CHAPTER 4 – RING SET UP**

- Section 4.1 – Footing
- Section 4.2 – Barriers
- Section 4.3 – Ring Layout

### **CHAPTER 5 – TEAMS AND TIME SHEETS**

### **CHAPTER 6 – MEASURING AND HEIGHT CARDS**

- Section 6.1 – Measuring
- Section 6.2 – Height Cards

### **CHAPTER 7 – REPORTING FOR RACES**

## **CHAPTER 8 – PRACTICE RUNS**

## **CHAPTER 9 – RULES OF RACING**

Section 9.1 – Jump Heights

Section 9.2 – The Heat

Section 3.3 – Aggressive Dogs

Section 9.4 – Lamé Dogs, Bitches in Season,  
Dogs Recovering from Surgery, Leg Wrapping

## **CHAPTER 10 – JUDGE’S AND STEWARDS**

Section 10.1 – Judges

Section 10.2 – Judges Guidelines

Section 10.3 – Judges and Stewards Duties

## **CHAPTER 11 – FLYBALL TITLES**

Section 11.1 – Points

Section 11.2 – Titles

## **CHAPTER 12 – RULE CHANGES**

Section 12.1 – Motions

## **CHAPTER 13 – INVESTIGATIONS**

Section 13. 1 – Investigations

## **Appendix A – Guidelines for Round Robin Competition**

## **Appendix B – Forms**

## **Appendix C – Typical Ring Set-Up**

## **Appendix D – Judges’s Guidelines (Condensed)**

## **Appendix E – Racing Schedules**

## **Appendix F – Judge’s Training Guidelines**

## CHAPTER 1 – CONDUCTING A SANCTIONED COMPETITION

### Section 1.1 - Requirements

- (a) The affiliate club must submit an application to the Controlling Body stating the date, time and place of the competition; the name, address and telephone number of the organiser; any entry fee; whether the entries are limited; the closing date; the name of the Judge(s); and any prizes and any special conditions.

Applications for unlimited entries are to be submitted at least sixty (60) days prior to the closing date. Applications for limited entries are to be submitted at least one hundred and twenty (120) days prior to the closing date. The application cannot be approved if another Controlling Body sanctioned competition is held on the same day in accordance with the following categories:

- (i) Within 100 kilometres if a local competition.
  - (ii) Within the state if a state competition.
  - (iii) Within the nation if a national competition.
- (b) All seeding and placing of teams in divisions is to be approved by the Controlling Body.
- (i) If it is necessary to run any division of less than 4 teams, it is recommended that this division be combined with an adjacent division. Division placements and break-out times for each individual division still apply.
  - (ii) The Controlling Body shall receive seeding and competition formats from the Competition organiser no later than 7 days before the competition.
- (c) The affiliate club must get written approval from the Controlling Body for any and all special or unusual requests.
- (d) All teams registered with the Controlling Body are to be notified via their Canine Journal of the date, time and place of the competition and the name and telephone number of the contact person prior to the closing date.
- (e) The affiliate club may not limit entries to less than four. In cases of limited entries, the affiliate club must accept entries by the date received. All the entries may be from the same club (i.e. Front Runners A team, Front Runners B team, Front Runners C team, Front Runners D team etc.). However, multiple entries of the same team are to be treated as one entry until after the closing date. Any remaining openings are to be filled by the second entry for those teams that enter more than one team, followed by the third entry for those teams that enter more than two teams and so on until the entries are filled.
- (f) ANKC recognizes two classes of competition: Regular and Non-Regular:
- (i) The ANKC Regular class of competition includes teams made up of any breed(s) of dog and/or mixed breeds and must be offered at every sanctioned competition.
  - (ii) A Non-Regular class (Pee-wee, Veterans, etc.), is any class other than the ANKC Regular class.

No dog shall be listed on more than one time sheet in any given class of competition. No dog shall be listed on the timesheets from more than one club at any given event. Dogs may not compete in more than one class at a Controlling Body sanctioned competition except:

- (i) When the competition's regular class is unlimited or;
  - (ii) When all entries received for a competition's limited entry regular class are accepted.
- (g) Following the competition, the affiliate club is to submit to the Controlling Body the original time sheets and entry forms, a Competition Results Form and competition records in accordance with Controlling Body rules.

### **Section 1.2 - Points**

Points towards Flyball titles will be awarded provided timesheets are signed by a Judge and Controlling Body Representative who are present and certifies that at least four (4) teams actually competed.

### **Section 1.3 -Format and Schedule**

The competition format and schedule shall be approved by the Controlling Body. The competition format includes:

- (i) Teams in each division along with the seed time of each team and the breakout time assigned to that division.
- (ii) Format of the competition, i.e., Round Robin with or without Single/Double elimination, and whether the two rounds are added together or not.
- (iii) Scoring – how wins and placings are determined; and how tie scores would be broken.

### **Section 1.4 - Seed Times and Break Out Penalties**

- (a) All teams are required to provide a seed time on entry forms.
- (b) Break Out time will be one (1) second faster than the fastest seedtime for each division (except Division I). When manual judging is used (in the absence or failure of the Electronic Judging System), the Break Out time will be two (2) seconds faster than the fastest seedtime for each division (except Division 1).
- (c) Penalty for first and second break out for the same team in a competition will result in forfeit of each heat in question.
- (d) Should a team break out three (3) times in a single competition, the penalty will be exclusion from placing in their division for the competition.
- (e) In any case, teams are entitled to all title points earned by their dogs in all heats.

### **Section 1.5 - Meaningless Heats**

Heats that are meaningless to the outcome of a sanctioned competition are not to be run just for the sake of allowing teams to accumulate more points toward Flyball titles.

## **CHAPTER 2 - RULES FOR COMPETITION**

### **Section 2.1 - Code of Ethics**

- (a) One of the objectives of the ANKC is to promote cooperation and good sportsmanship in the training and exhibition of dogs. Cooperation and good

sportsmanship should not be recognised in passive observance, but as a way of life in training and competition. Participants shall at all times be courteous and friendly. At no time should they show displeasure with a dog, a Judge, exhibitor, Controlling Body Representative, sponsor, affiliate or spectator, in or out of the ring.

Never conduct yourself in a manner that would bring discredit to the sport of Flyball. As a participant, whether it be exhibitor, trainer, Judge, affiliate club or Controlling Body Representative, you typify the sport of Flyball.

- (b) Training and exhibiting shall be carried out by such methods that keep in the best interest of the dog and the sport of Flyball.
- (c) Abuse or severe disciplining of a dog (e.g. shaking, smacking, kicking etc.) is not in the best interest of the sport of Flyball. **Abuse may include the running of dogs that are not one (1) year of age.**
- (d) Participants shall always follow the rules, showing knowledge and an understanding of the same.
- (e) Any individual or club may file a protest or prefer charges against another individual or club for alleged misconduct, in or out of the ring, prejudicial to the best interest of the sport of Flyball as provided for under Section 2.2.

Protest filed during competition should be done in such as manner as not to bring discredit to the sport of Flyball.

## **Section 2.2 - Misconduct**

Misconduct shall include, but not be limited to, abusive or foul language, demonstration of dissatisfaction with a Judge's decision, inhumane treatment of a dog, demonstration of poor sportsmanship, wilful violation of the rules with the intent to gain an unfair advantage or any other behaviour or altercation that would leave a spectator or exhibitor with an unfavourable opinion of the sport of Flyball.

## **Section 2.3 - Amateur Competition**

The ANKC conduct amateur competitions.

## **Section 2.4 – Changing Teams**

- (a) If a dog has raced in a Controlling Body sanctioned competition, the dog may not race with another team for four (4) months. This does not apply when changing teams within a club (e.g. from Front Runners A team to Front Runners B team). Any deviation from this rule requires the team to run "non-competitive" and no ANKC points will be awarded.

Exceptions are as follows and must be approved by the Controlling Body:

- (i) The handler/dog has moved to another area.
- (ii) Team agrees to dissolve
- (iii) A new team is formed. Once the dog has joined a team, that dog may not run with another team, new or existing, for a period of four (4) months. A team is considered to be "new" until they race in their first Controlling Body sanctioned competition.

A dog/team waiting for exemption approval from the Controlling Body may still enter a competition pending Approval. (see also Chapter 7 (e))

## **Section 2.5 - Protest**

Should a protest be lodged at a competition, that protest should be lodged before the commencement of the next heat. Further protests shall be submitted, in writing, to the Controlling Body for appropriate action in accordance with their rules.

## **Section 2.6 – Signal Cards**

**Yellow Card** – Indicates a formal “caution” for any of the following offences:

- (a) Not being courteous and friendly in manner.
- (b) Purposely delaying the restart of a heat.
- (c) For showing displeasure with a dog, a Judge, Stewards, Controlling Body Representative, affiliate club, other exhibitor/s or spectator/s in or out of the ring. This includes showing dissent by word or actions.
- (d) Demonstration of poor sportsmanship.
- (e) For entering the ring to set up for a new race before the Judge has declared the previous race.
- (f) First offence for interference.

The Judge shall hold up a Yellow playing card-sized card (preferably laminated) to inform an ANKC/AFA Member of inappropriate behaviour. The Judge shall inform the ANKC/AFA Member and Team Captain of what the infringement is being applied for and shall submit a report to the Controlling Body Representative.

**Red Card** – Indicates to an ANKC/AFA Member that they are to be “Sent Off” for 3 heats for any of the following offences:

- (a) Any other behaviour or altercation that would leave a spectator/s or exhibitor/s with an unfavourable opinion of the sport of Flyball.
- (b) Inhumane treatment of a dog (Includes racing a dog under 12 months of age).
- (c) Abusive or foul language.
- (d)** Demonstration of dissatisfaction with a Judge’s decision. This includes approaching stewards or timekeepers to question them about the decision.

A Red Card will also represent a second incident of any offence listed under the yellow card.

The Judge shall hold up a Red playing card-sized card (preferably laminated) to inform an ANKC/AFA Member of inappropriate behaviour. The Judge shall inform the ANKC/AFA Member and Team Captain of what the infringement is being applied for and the ANKC/AFA Member will be “Sent Off”. The ANKC/AFA Member and their dog must exit the racing ring for the following 3 heats that they will be involved with even if it is in a following race. The Judge shall submit a report to the Controlling Body Representative.

**Black Card** – Indicates the ANKC/AFA Member is to be excused from the remainder of the competition for any of the following offences:

- (a) Wilful violation of the rules with the intent to gain an unfair advantage. (This includes sandbagging).
- (b) Aggression whether it be between dogs or handlers. It will also include a dog that is suspected of aggression.

A Black Card is also used for a third incident of any offence listed under the Yellow Card and a second incident under the Red Card.

The Judge shall hold up a Black playing card-sized card (preferably laminated) to

inform an ANKC/AFA Member of inappropriate behaviour. The Judge shall inform the ANKC/AFA Member and Team Captain of what the infringement is being applied for and the ANKC/AFA Member will be "Excused for the remainder of the Competition or Demonstration". The Judge shall submit a report to the Controlling Body Representative.

### **Section 2.7 - Record Times**

The minimum requirement for having an Australian record time recognised is to:

- (a) Have electronic timing;
- (b) A continuous video of the heat showing the time sheet after the completion of the heat. The video must be in line with the start finish line, with a clear view of the sensor panels, and the light tree. The continuous video must also have a date and the frame counter activated at the time the video evidence is taken.
- (c) All passes / exchanges must be clean to qualify for an Australian record.
- (d) The electronic judging system must not show any errors or faults and show the heat time after the green light for declaring the winner has been activated.
- (e) The heat should be timed with a stopwatch when the video is reviewed. The hand timing is to confirm that the tape is of the actual run in question.
- (f) To verify a new AFA/ANKC record time the Judge must verify the following using the appropriate form. Race lane length, jump placement, box throw, jump heights, and height dog measurement.
- (g) *ANKC registered teams may attempt an Australian at an AFA sanctioned competition and apply for the record time to be recognised on the appropriate AFA form.*

## **CHAPTER 3 - EQUIPMENT**

### **Section 3.1 - Flyball Boxes**

- (a) Each team shall supply a Flyball box.
- (b) All boxes are to have a mechanical (not electrical) pedal release mechanism.
- (c) The boxes may be painted or decorate as the team wishes.
- (d) The ball, when released, must have a free unobstructed flight of not less than 609.6mm (24 inches) from the point that the ball is released, in the direction of the start/finish line from all holes.
- (e) Boxes:
  - (i) Shall not exceed 609.6mm (24 inches) in width, nor 457.2mm (18 inches) from the bottom surface of the box excluding mat grabbing devices/materials and outdoor staking devices.
  - (ii) The body of the box shall not exceed (762mm) 30 inches in depth.
  - (iii) The dimensions include the throwing arm, but do not include any platform the box loader uses to stand on.
  - (iv) Mat grabbing devices/materials shall not raise the box by more than one half inch;
  - (v) The box shall not exceed these dimensions at any time during racing (including any permanent attachments to the box, i.e. carrying handles, cocking devices).

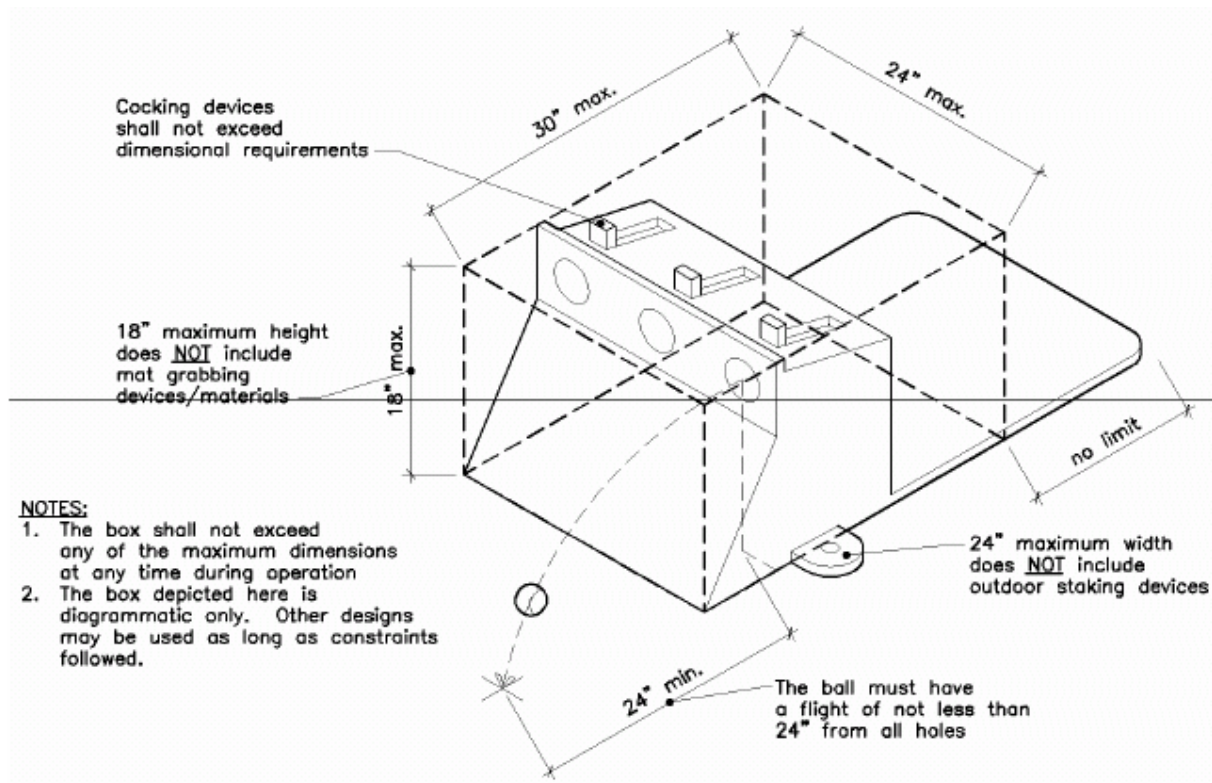

### Section 3.2 – Balls

Each team shall have its own supply of unpunctured, regulation tennis balls (any colour). Subject to the size and comfort of the dog, squash balls, racket balls, or approved balls may be used. Approved balls must function similar to a tennis ball (i.e. they must bounce and roll).

### Section 3.3 – Jumps

- (a) The affiliate club shall provide two sets of regulation (identical) jumps for the duration of the Flyball competition. Teams are asked to cooperate by lending equipment.
- (b) The jumps shall be solid flat white except for the uprights (posts), which may be any colour. The jumps shall have an inside width of 609.6mm (24 inches), with uprights (*posts*) not more than 914.4mm (36 inches) high nor less than 609.6mm (24 inches) high. Logos and/or lettering on the cross-boards will be permitted but must maintain a 50.8mm (2 inch) white border around all four edges inside the post.
- (c) Jump heights shall be set 101.6mm (4 inches) lower than the height at the withers of the smallest dog on the team (running not stand-by), to a minimum of 203.2mm (8 inches). Maximum jump height shall be 406.4mm (16 inches).
- (d) Jump heights shall be adjusted to 25.4mm (1 inch) increments, to the lowest whole number (374.7mm (14 3/4") becomes 355.6mm (14")).
- (e) The top of the jumps may be padded.
- (f) Jump slats made of any material that are broken or bent must be removed from competition.

- (g) Jumps shall be within ¼" in tolerance for height

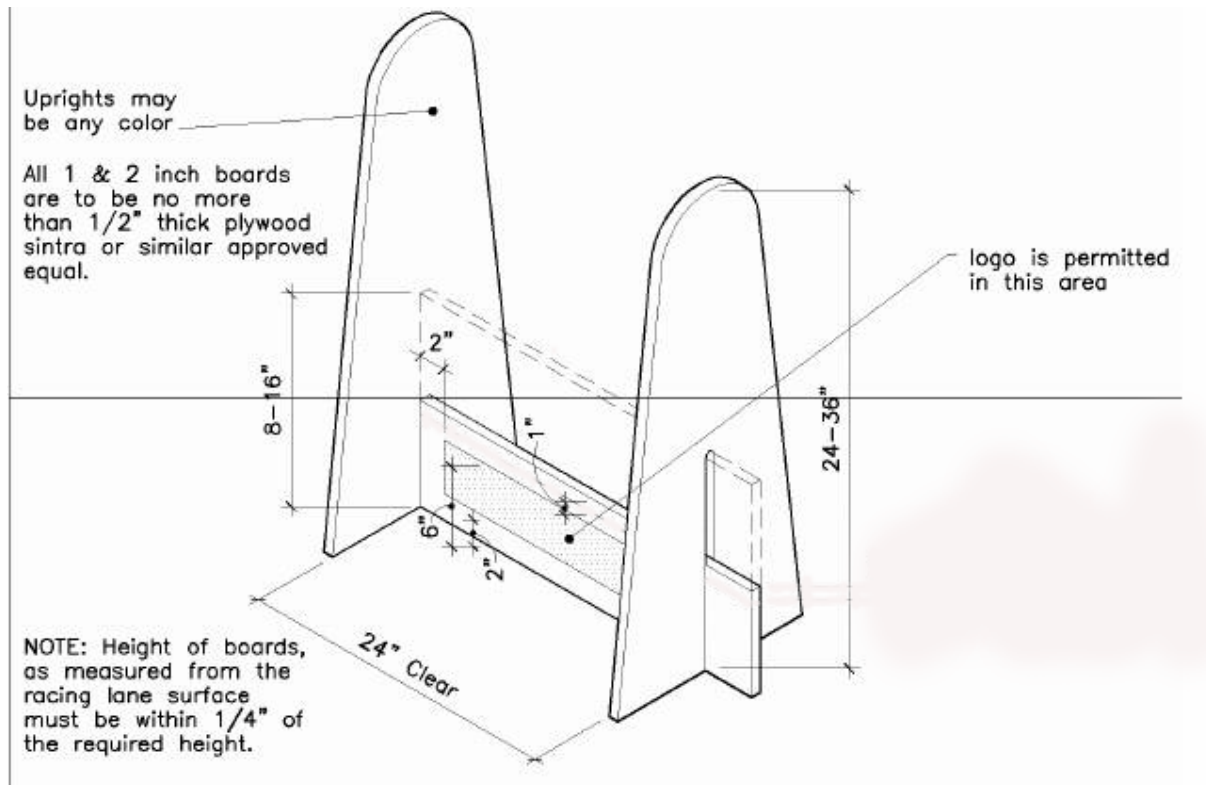

## CHAPTER 4 - RING SET-UP

### Section 4.1 – Footing

The affiliate club shall provide adequate non-slip footing on the racing lane, at the box and at the start/finish if racing indoors.

### Section 4.2 – Barriers

The affiliate club shall provide a barrier/backstop (minimum 609.6mm (24 inches) high) at the box end of the run, placed so as to prevent missed balls from rolling too far but placed so as not to prevent proper observation by the Judge or to obscure the spectators view.

A barrier (minimum 609.6mm (24 inches) high) shall extend between the boxes, up to 2 feet in front of the box placement line to minimise interference. Barriers shall not comprise jumping equipment.

### Section 4.3 - Ring Layout

- (a) There shall be a distance of 1.83m (6 feet) from the start/finish line to the first jump, 3.05m (10 feet) between each jump (four (4) in total) and 4.57m (15 feet) from the last jump to the front edge of the Flyball box. The start/finish line shall be clearly definable, bearing in mind the safety of the handlers and dogs.
- (b) Racing lanes are to be a minimum of 3m (10 feet) apart with a maximum of 6.1m (20 feet) apart.

- (c) The minimum area required for two regulation lanes is 9.1m (30 feet) by 27.4m (90 feet).

In cases of racing lanes being placed on hard surfaces or carpet (such as indoor/outdoor carpet where rug bums are possible) each racing lane shall be matted at a minimum 1.4m (4 1/2 feet) on either side of the racing lane centre line for the length of the racing lane leading up to the first jump and an area from the last jump to the backstops.

Where sod, dirt, grass or similar surfaces are available matting shall not be required. All racing surfaces must be free of apparent contaminants.

The length of the racing lane shall include an area not less than 8.8m (29 feet) leading up to the start/finish line and an area behind the Flyball box and in front of the backstops to a minimum of 5 feet and that the backstops may protrude up to 2 feet in front of the box line.

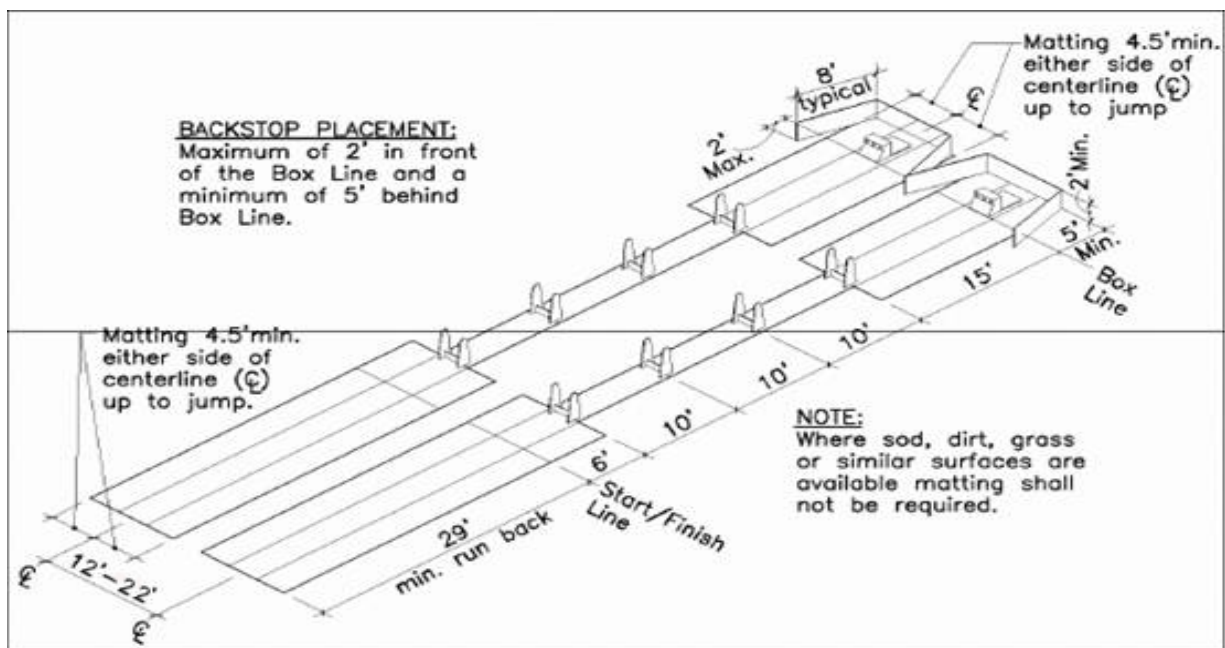

## CHAPTER 5 – TEAMS AND TIMESHEETS

- (a) Each team is to consist of a minimum of four (4) dogs and four (4) handlers, with a maximum of six (6) dogs and six (6) handlers, plus a box loader and, at the discretion of the team, a runner or two to pick up loose balls, set up knocked down jumps and to otherwise assist the team, providing doing so does not interfere with the Judges, nor the opposing team, nor in any way assist the dogs or violate the rules.
- (b) Each team is to have four (4) dogs running in each heat, with a maximum of two alternates as standbys close at hand. The reserve(s) may be used at the team's discretion or in the case of an injury. Substitutions may only be made at the end of each heat.

Each dog on the team including the reserves must be declared prior to the competition. Once the competition has begun there will be no substituting of the dogs entered on the team.

- (c) The Time Sheet shall include the team name; the team captain's name, each dog's name, breed, Competition Registration Number (CRN) and jump height; each handler's name and the name of the box loader.
- (d) For multiple entries of the same team, there will be no switching of dogs from one team to the other once the competition begins.
- (e) The dog's ANKC Registered Number shall be used to identify the dog throughout its racing career.
- (f) Any dog entered in a Controlling Body sanctioned competition without a valid ANKC Registered Number will result in forfeiture of all points and event placements for that team.

All Competitors will wear a tag displaying the ANKC Registered Number of the dog that the competitor is handling whilst racing in the ring at a sanctioned competition. The number must be of a suitable size to be easily read by the Judge, Stewards and Timekeepers.

The first offence of a handler's failure to comply shall receive a warning. A second offence or any offence thereafter during the competition will result in the loss of the heat.

*(See also Chapter 2 – section 2.4 Changing Teams and Chapter 7 – Reporting for Races).*

## Chapter 6 – MEASURING AND HEIGHT CARDS

### Section 6.1 - Measuring

- (a) At the discretion of the team, dogs jumping less than 16 inches may be measured by the measuring Judge officiating at the competition during times designated by the affiliate club. A dog must be entered in the competition in order to have its height recorded on a Height Card Application.
- (b) If the Judge determines that a team is not jumping at the correct height in a round robin format, the team shall forfeit all heats run at the improper jump height.
  - (i) In the case of an elimination format, the team shall be excused.
- (c) The Judge may at any time measure a dog.
- (d) Once the dog is measured, the Judge is under no obligation to re-measure the same dog.
- (e) If a dog is re-measured and the measuring Judge determines he has made a mistake, the team shall in no way be penalized. However, the team will be required to jump the proper height for any remaining heats.
- (f) Any protest with respect to a dog's jump height must be verbalized to the Competition Organiser and/or the Controlling Body Representative within 30 minutes of the heat in question by the Captain of a competing team in that division or combined division.

- (g) Measurements are to be open to public observation.
- (h) Only one (1) handler per dog shall be allowed in the measuring area.
- (i) Aggression during measurement will not be tolerated and **Section 9.3** (Aggressive Dogs) will be observed.
- (j) A team's height dog deemed to be "NOT MEASURABLE" by the measuring Judge may be excused from competition.
- (k) Height measurements are to be recorded and signed by the measuring Judge. In cases where multiple Judges are measuring, once a dog's height has been measured and recorded by either Judge, that shall be the dog's official jump height for that competition, regardless of which ring the dog may run in.
- (l) The measurement area will be determined by the measuring Judge. The Judge shall select an appropriate measuring surface. Prior to measuring the first dog, and any time it is moved, the measuring device shall be calibrated to ensure accuracy. If the Judge determines that an appropriate measuring surface or that an ANKC approved measuring device is not available, measuring shall be for the competition only and not for an ANKC Height Card Application.

**Dog standing properly to be measured.**

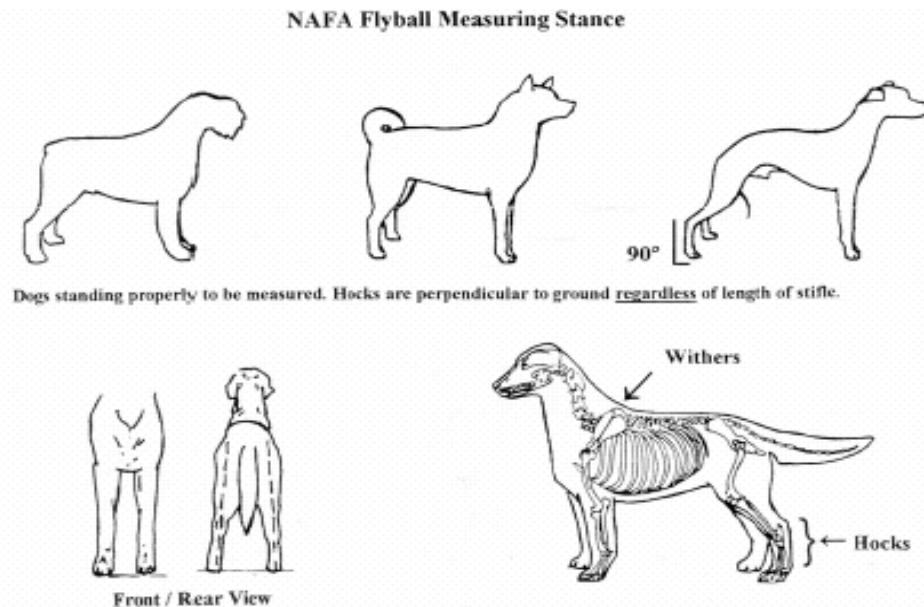

- (m) The dog's height shall be measured from the ground to the top of withers with the dog standing in an upright position as indicated by Illustration above. The handler may steady the dog if necessary, but shall not physically support the dog during the measuring process.

The front legs will be vertical with the paws directly below the shoulders. The back legs will be positioned with the hocks perpendicular to the ground and spread no wider than the width of the dog. The dog's entire head is to be in an upright position above the level of the withers as shown in the above Illustration. The dog may be measured up to 3 times. The height measurement shall go to the lowest height for the benefit of the dog.

- (n) Height Cards are to be optional.

## **Section 6.2 - Height Cards**

Height cards are optional and may be applied for by submitting a completed application form. There are a number of requirements:

- (i) Dog must race for at least 12 months before its first measurement.
- (ii) Dog must be micro chipped prior to its first measurement (random checks will take place at competitions).
- (iii) The form must be presented to the Judge before the dog is measured.
- (iv) The form is considered complete when a dog has received the same measurement three (3) times by three (3) different Judges. Only one height card measurement may be attained per competition. The measuring Judge must be an approved ANKC Judge, but not necessarily officiating at the competition.
- (v) The microchip number must have been verified at least once.
- (vi) When the application form is complete, it must be forwarded to the Controlling Body with the appropriate application fee. The form will be verified and a height card issued.
- (vii) The height card must be presented at each competition; otherwise the dog is subject to normal measuring requirements.
- (viii) Height cards issued by the Controlling Body will be wallet-size laminated cards and will be good for the life of the dog. Once a height card has been issued, additional cards for the same dog may not be applied for. Lost height cards can be replaced with an identical card for an appropriate fee.

## **CHAPTER 7 – REPORTING FOR RACES**

- (a) If one or more team members are more than five minutes late for the scheduled start of a race, all else being in readiness, the Judge may declare a forfeit by that team. This is a discretionary rule, since its main purpose is to avoid undue delays at the competition for spectators and competitors alike.
- (b) Teams that win by forfeit must complete the minimum required heats scheduled to qualify for points awarded in the round robin or to advance in double elimination competition. If another team is not available to compete the team shall race without an opponent.
- (c) Forfeiting teams that do not show just cause will be excused from the competition by the competition organiser and may be subject to further discipline. Forfeiting teams may not run any dogs in the heats that are forfeited. If a team forfeits a heat and then subsequently runs a dog(s) in violation of this rule, they will automatically be considered as Non-Competitive.
- (d) If a team has to forfeit when their "A" and "B" teams are in the same race, the faster team must run and the slower team must forfeit. If the faster team wishes to forfeit they will forfeit for the rest of the competition.
- (e) Once a team declares themselves, non competitive, they cannot return to regular competition. From that point on, the team can no longer obtain ANKC points or competition points. Non-competitive teams may not run if the opposing team raises an objection with the Judge. Once teams declare themselves non competitive, they

are ineligible for placement and shall be placed in the lowest seed of any eliminations. A club cannot enter a team into a Controlling Body sanctioned competition to run non-competitive only. A team running as non-competitive only is subject to all the rules of competition with the exception of the following:

- (i) 3 or 4 dogs may be run in a heat;
- (ii) False starts are not in affect;
- (iii) Any jump height from 8" to 16" is allowed at the discretion of the team; *(any changes will be in accordance with the AFA)*
- (iv) In the event a dog receives a flag, it may complete its run but not rerun;
- (v) The Judge may excuse the team from the race for failure to comply with these conditions or other ANKC rules.

## CHAPTER 8 – PRACTICE RUNS

- (a) There shall be a designated time period for warm-ups.
- (b) There shall be no practice or training in the ring for the duration of the competition except for the practice runs as permitted just prior to each race. Individuals may work with the Flyball box or on jumps outside the ring provided it does not distract other teams.
- (c) Training in the ring during the competition will mean a forfeit of that heat. When a team is delayed by a ring conflict, warm-ups shall not begin until both teams are present in the ring. Teams already present and waiting may set their jumps and place their box.
- (d) Only dogs listed on the team's timesheet are allowed to warm up. Each dog must have a valid ANKC Registered Number and be eligible to compete. Any dog(s) that warm up in violation of this rule will cause the forfeiture of all ANKC title points earned during the competition for all dogs on the timesheet. The team with the dog that violated this rule will also forfeit any competition placement.
- (e) Flat collars and harnesses are the only acceptable type of collar.

## CHAPTER 9 – RULES OF RACING

**(See also Section 1.4 Seed Times and Break Out Penalties)**

### Section 9.1 – Jump Heights

- (a) Jump heights shall be set at a minimum of four inches lower than the height at the withers of the smallest dog on the team (running in that heat), to a minimum of 8 inches. Maximum jump height shall be 16 inches.
- (b) Jump heights shall be adjusted in one inch increments, to the lowest whole number (14 and 3/4 inches becomes 14 inches).

### Section 9.2 – The Heat Definition:- Three or five heats make one race

- (a) The start:  
Dogs may start from a stationary or running start.

When using a manual start (Judge's whistle), if any part of the dog's body, whether in the air or on the ground, or any part of the handler's body or their objects passes (*if the handler's feet*) are over the line before the whistle is blown, will be an infraction, to be called by line steward or Judge.

When electronic starting lights are used, any part of the dog or handler's body or their objects breaking the beam before the start will constitute a false start and will be called by the EJS and Judge. The heat is to be restarted.

If a second such infraction is called against the same team (for that heat) the dog must run again. If a second false start is called coincidental with the opposing teams first false start the heat is to be restarted.

(b) The run:

Dogs may start from a stationary or running start. Each dog is to hurdle the four (4) jumps in succession, trigger the box and return over all four (4) jumps with the ball in its mouth. Only when the first dog has reached the start/finish line with any part of its body (on the ground or in the air), may the second dog reach the Start/finish line with any part of its body (generally this is a nose to nose pass at the start/finish line), and so on for all four (4) dogs as well as dogs that must run again.

Early passes will be indicated by the Electronic Judging System (EJS) or in cases of EJS failure the line steward, thus the dog will be required to run again after the other dogs have run.

If a dog reaches the start/finish line before the preceding dog has reached the start/finish line, or does not take every jump, or does not trigger the box, or takes the ball from the cup, or does not return with the ball, the dog must run again.

If the handler's feet cross the start/finish line during his/her dogs run, the dog must run again (with the exception of setting up a knocked down jump or retrieving a loose ball).

(c) Knocked down jumps:

A dog that knocks down a jump(s) during its run shall not be penalised, provided the dog(s) clear the jump as if it were standing. A "runner" or handler may set up knocked down jump(s) providing doing so does not interfere with it or guide the dog in any way.

(d) Box Malfunction:

The box loader shall indicate to the box steward and Judge when there is a box malfunction (stand in front of the box and wave your arms). The heat shall be stopped. The Judge is to examine the box. If, in the opinion of the Judge, the box has malfunctioned the heat shall be run again. If the box is found to be working then the heat shall be forfeited. If another box is not available and the box cannot be repaired in a reasonable time, the heat and any remaining heats are to be forfeited. If the box malfunctions a second time (or the spare box malfunctions) in the same race, the heat shall be forfeited and all remaining heats in that race shall be forfeited.

(e) Intervention:

Should the ball bounce back in the cup as the dog tries to catch it, the box loader may re-set the box for the dog to trigger it (without penalty). This is the only time at

which the box loader is permitted to signal a dog to push the pedal.

- (f) **Fouling:**  
*(If a dog relieves itself in the ring the team forfeits the heat.)*  
If a dog relieves itself in the racing ring at any time prior to the first heat or between heats, the dog's team forfeits the next heat.
- (g) **Out of bounds/Out of play:**  
The affiliate club shall specify the race area boundaries. If a ball bounces out of bounds and the dog retrieves the ball unaided, there shall be no penalty. If the dog is aided by a spectator, handler, box loader or other, the dog is to run again.

Out of play shall be the same as if the ball were out of bounds. For example; if the ball becomes lodged or trapped inside the box.

- (h) **Conduct of the box loader:**  
Except during the warm up, to retrieve a loose ball or get a fresh supply of balls to load for the current heat, the box loader must remain in the upright position behind the box, and may offer verbal encouragement only, as long as such encouragement does not distract the opposing team. The box loader is to remain in position until the Judge determines the outcome of the heat. If, in the Judge's opinion, a box loader has violated any of these rules, his/her team may forfeit the heat. If, in the opinion of the Judge, a box loader assists a dog, except where provided for in the rules, the dog shall run again.
- (i) **Interference:**  
A dog or any team member interferes with the opposing team during a heat; the team causing the interference will forfeit the heat. This includes interference in the racing lane, in all in bound areas, and in the area where dogs are waiting to run. Interference is described as crossing the imaginary centre line and becoming a safety hazard to the dogs racing in the other lane and obstructing the other team's dog from running its race.

A dog chasing its team's loose ball into the other team's area is not necessarily interference.

An example of interference is when "Team A" and "Team B" were racing. A ball from "Team B" rolled across to the edge of "Team A's lane next to a jump. Two dogs from "Team A" ran by the ball without incident. The third dog however, stopped and picked up the ball. This is interference on "Team B" because the ball was from their lane. Even though the first two dogs ran past the ball, the ball was not supposed to be there and by its presence it prevented "Team A" from completing it's run.

- (j) **The finish:**  
The first team to have all four (4) dogs successfully complete a run wins the heat. The finish shall be when the last of the four (4) dogs reaches the finish line with any part of its body, in the air or on the ground. A competition may be won due to default by the opposing team according to the rules of racing.
- (k) **Distractions:**  
Team members shall not distract the opposing team by bouncing balls, using a Flyball box at the end of the run, or by any other means nor by throwing any object for their dogs (i.e. balls, toys, Frisbees, dummies, gloves or treats).

Team members are required to pick up loose balls.

The first offence of any of these infractions shall receive a warning. A second offence or any offence thereafter during the race will result in the loss of the heat.

- (l) Broken boards:  
The heat shall not be stopped for broken boards, unless, in the opinion of the Judge, the dog(s) may be subject to injury. If the heat is stopped by the Judge to prevent a possible injury, the heat is to be restarted.
- (m) Safety Hazards: If, in the opinion of the Judge, a safety hazard exists during the running of the heat, the heat shall be stopped and rerun.
- (n) Fouls: Dogs that receive a foul must be rerun after the initial four dogs in the order they were fouled. Racing infractions requiring the rerunning of a dog include:
  - (i) Early passes will be indicated by the EJS and the Line Steward and/or the Judge. When running without an EJS system, the line Judge will indicate an infraction;
  - (ii) Missed jumps;
  - (iii) Not carrying the ball over each jump in succession;
  - (iv) Does not trigger the box;
  - (v) Dog takes the ball from the cup without first triggering the box;
  - (vi) Does not carry the ball over the start/finish line;
  - (vii) Inappropriately assisted by the boxloader, spectator or handler;
  - (viii) A handler or their object crosses the start/finish line during the dog's run (with the exception of resetting knocked down jump(s) or retrieving loose ball(s)).
- (o) Winner: Determining the winner of a heat
  - (i) When a heat is judged using the Electronic Judging System, the winner of close heats shall be determined based on the Electronic Judging System times. When the times are within .003 of a second (for example, a time of 21.798 versus 21.801) the Judge shall declare the race to be a tie;
  - (ii) When a heat is judged to be a tie with manual judging (in the absence or failure of the Electronic Judging System), the Judge's shall confer with the line stewards and their decision as to the winner of the heat must be unanimous and shall be based on their visual view of the finish line, not on the stopwatches. If the Line stewards are not in agreement, the Judge shall consult with the Line stewards and either declare a winner or declare the heat to be a tie.
- (p) Determining the winner of a race:  
In the event that each team competing in a race win an equal number of races (due to dead heats) an extra heat shall be run.

### **Section 9.3 - Aggressive Dogs**

If a dog shows aggression toward another dog or handler, at any time during the competition, the Judge may excuse the dog from competing and a standby dog is to be used. The degree of aggression that warrants substitution is to be determined by the Judge. The Judge must report any dog excused from competition to the Controlling Body in accordance with their Constitution and Rules.

### **Section 9.4 - Lamé Dogs, Bitches in Season, Dogs Recovering from Surgery, Leg Wrapping**

Wrap on dog's legs may be used with the prior approval of the Judge. If, in the opinion of the Judge, a dog is lame, in season, recovering from surgery, obese or for a related reason should not compete; the same shall be excused from competition.

## **CHAPTER 10 - JUDGES**

**Section 10.1- Judges** - Also Refer to Appendix E -'Judges Guidelines (condensed)".

- (a) One (1) Judge five (5) stewards and two (2) timekeepers shall officiate when two teams are running.
- (b) Two (2) stewards shall be positioned at each team's starting line, facing each other; two (2) stewards are to be located at the box end, with a good view of the box loader, but not positioned (sitting) so as to interfere with or distract the dog; one (1) steward shall be positioned (sitting) in the middle at the rear of the ring in the inbound area; two (2) timekeepers shall be positioned at the timekeeping table and the Judge shall also act as starter and referee.
- (c) The box stewards, line stewards, inbound steward and timekeepers shall remain stationary during each heat; dogs may go around stewards and balls bouncing off a Judge, Steward or Timekeeper shall be deemed in play. The principle responsibility of each box steward, each line steward, inbound steward and each timekeeper is to watch for violations in the racing lanes that they are assigned to. Stewards, Timekeepers and Judges must not offer verbal encouragement to teams.
- (d) The Judge (starter and referee) shall be positioned between the racing lanes in the area between start/finish line and the starting dogs to start the heat. During the heat the Judge should be in a position to observe the handlers for any violations. Finally, if necessary, the Judge (starter and referee) should be in a position to assist the line stewards in determining winners of close heats. The Judge should always confer with the line stewards, the box stewards, the inbound steward and timekeepers before determining a winner.

If necessary, a Judge shall reposition himself/herself in such a manner as not to distract the dogs competing.

The Judge shall maintain a consistent starting cadence of approximately one (1) second intervals throughout the competition.

- (e) All Judges should have a clear understanding of the rules and shall be impartial.
- (f) Stewards shall indicate with a signal, which dogs must rerun. It is the handler's responsibility to note the signal and rerun his/her dog. If it is necessary to stop a heat, the Judge shall use a whistle.
- (g) Persons interested in becoming an approved ANKC Judge must complete successfully the Provisional Judges training program.
- (h) The minimum age for Judges, Stewards and Timekeepers is 18 years of age.

### **Section 10.2 - Judge's Guidelines**

- (a) Judges shall be friendly and courteous, even sympathetic, but above all impartial and firm. Judges must have a thorough understanding of the ANKC Rules and the sport of Flyball gained through personal experience.
- (b) The Judge's responsibility also extends to the exhibitors, to the affiliate club to the spectators and sponsors. A Judge must be arbiter and diplomat. A Judge must leave exhibitors and spectators with the feeling that each team was given an equal opportunity and no team was given an unfair advantage.
- (c) A Judge is not to engage in conversation with a disgruntled exhibitor. The Judge may excuse any person for breach of the Code of Ethics.
- (d) Upon arriving at the site, a Judge shall immediately report to the competition organiser. A Judge shall be at their ring at least one half hour before the competition to check the ring, jumps, matting and backstops. If dogs are to be measured and boxes inspected before the competition, the Judge shall allow additional time as directed by the competition organiser.
- (e) The rules are a basic guide. They should not be considered a manual containing explicit direction for every possible situation. Judgment calls should be based on the experience, good character, fairness and consistency of the Judge. The intelligent application of discretionary authority demands a Judge exercise common sense, fairness and initiative. Above all else, **the safety and welfare of the dogs and exhibitors shall be foremost.**
- (f) When a single breakout occurs, the time is recorded on the timesheet with BO written next to the time and the heat is awarded to the team that did not breakout. This is the same for the next two breakouts by the same team. After the third breakout, the team has forfeited the right to place in the competition but has not forfeited the right to win the heats. So if that team continues to breakout, a loss will be recorded for that team as well as a time for each heat and BO will be written next to the times. When the timesheet is calculated for a round robin racing format, the round robin points will be recorded only on the races that did not involve the team that broke out, for the entire division. A team that has already broken out in a preceding round robin format would not be eligible to race in either single or double elimination racing to decided the placings of the competition. If a team breaks out in an elimination racing format prior to the round robin format starting, they would be excused from any more elimination races, but could participate in the round robin format of the competition. Under the new points system (adopted 1<sup>st</sup> January 2006), a team that has broken out three times in a competition can only win a maximum of one title point per heat completed with four dogs.
- (g) If a team is interfered with, the team gets one bonus title point for the win and no points for the completion.

Judges shall not assist teams during warm ups.

*For further interpretation and application of Flyball Competition Rules only refer to the AFA Judges Manual available on the AFA Website [www.flyball.org.au](http://www.flyball.org.au).*

### **Section 10.3 - Judges and Stewards Duties**

- (a) Prior to the scheduled time for competition, the Judge shall inspect the ring. It must meet all the requirements of the ANKC Rules.

- (i) The start/finish line shall be clearly marked.
  - (ii) Jump placement, jump heights. A deviation of 6.35mm (1/4 inch) on the jump heights is considered minor and acceptable.
  - (iii) Backstops, barriers and box location shall be measured to make sure they meet the requirements of the regulations.
  - (iv) Each box shall be inspected by the panel of Judges and shall not be allowed if, in the opinion of the panel of Judges, the box has been constructed or altered in a manner that does not meet the box requirements.
- (b) Dogs that require measuring must be measured by the Judge prior to the start of the competition as per Section 6.1.
- (c) The Judge shall stop the heat for interference, fouling in the ring, for the first false start for which the heat is to be restarted or aggression by a dog or handler and award that heat to the opposing team.
- (d) Timekeepers shall:
- (i) Record which dogs participate in every heat using the ANKC Time Sheet.
  - (ii) Operate the EJS for the duration of each heat. They will ready the EJS before the start of each heat. The EJS will signify when there has been a false start or a bad changeover (pass). The timekeeper is required to press the manual foul for their assigned lane when a dog misses a jump, a dog does not carry the current ball across the start/finish line in its mouth, a dog does not trigger the box, a dog fouls in the ring, if a handler crosses the start/finish line during a heat (other than to set up a knocked down jump or to retrieve a loose ball) or other role violations for which a dog must run again.
  - (iii) Record any violations on the team's timesheet as per the Judge's instructions.
  - (iv) At the end of the heat the timekeeper is required to record on the timesheet the recalculated time on the time sheet given by the EJS after the EJS has declared the winner and record the winner.
  - (v) Check for breakouts and notify the Judge if a team has run a breakout time.
  - (vi) Mark when a manual time has been used due to EJS failure.
  - (vii) When manual timing is used instead of the EJS the timekeepers will become the backup timers to the Line Stewards. The Line Stewards time will be recorded on the timesheets.
- (e) Line Stewards shall:
- (i) Record times on a stop watch for each heat run in case of EJS failure.
  - (ii) Signal with a flag when their assigned lane has fouled ie; when a dog misses a jump, a dog does not carry the current ball across the start/finish line in its mouth, a dog does not trigger the box, a dog fouls in the ring, if a handler crosses the start/finish line during a heat (other than to set up a knocked down jump or to retrieve a loose ball) or other role violations for which a dog must run again.
  - (iii) Confer with the Judge following each heat to determine the winning team.
  - (iv) When manual timing is used instead of the EJS the line steward becomes the main timer and is required to raise their flags for false starts, illegal passes in their assigned lane. They will also watch for close finishes.
- (f) Box Stewards Shall:
- (i) Observe that the box loader or spectators do not assist the dog racing.
  - (ii) Signal to the Judge for box a malfunction (box loader to indicate to the box steward if the box malfunctioned).

- (iii) Signal by raising their flag when a dog fouls in the ring, misses a jump, a dog does not trigger the box, or the box loader or spectator assists the dog in any manner that is not provided for in the Rules.
- (g) Inbound Steward shall watch for:
  - (i) Throwing of motivators or balls
  - (ii) Other distraction incidents
  - (iii) Aggressive incidents involving dogs and/or handlers
  - (iv) Incidents of Interference.
  - (v) Handler indiscretions and inform the Judge at the end of each heat if any of the above violations occurred.

## CHAPTER 11 – FLYBALL TITLES

### **Section 11.1 - Points**

Teams racing in a Controlling Body sanctioned competition will receive 1 point towards their Flyball title for each dog racing in that heat when all four dogs complete the heat correctly without requiring any reruns. If that team wins the heat each dog running will receive another 1 point towards their Flyball title.

For title points to be awarded, an ANKC Judge or Controlling Body Representative must be present and at least four (4) teams must compete. All four teams may be from the same club provided each team registered with the Controlling Body was given an equal opportunity to enter but choose not to.

### **Section 11.2 - Titles – under new Title Points system**

- (a) ANKC will award a certificate of achievement and title “Flyball Dog” (FD) to any dog receiving 5 points.
- (b) ANKC will award a certificate of achievement and title “Flyball Dog Excellent” (FDX) to any dog receiving 20 points.
- (c) ANKC will award a certificate of achievement and title “Flyball Dog Champion” (FDCh) to any dog receiving 50 points.
- (d) ANKC will award a certificate of achievement and title “Australian Flyball Champion” (AFCh) to any dog receiving 150 points.
- (e) ANKC will award a “Flyball Master” (FM) Pin for any dog receiving 400 points.
- (f) ANKC will award a “Flyball Master Excellent” (FMX) Pin for any dog receiving 700 points.
- (g) ANKC will award a “Flyball Master Champion” (FMCh) Pin for any dog receiving 1000 points.
- (h) ANKC will award the “Onyx” Plaque, named after its first recipient, for any dog receiving 1300 points.
- (i) ANKC will award a “Flyball Dog Grand Champion” (FDGCh) Plaque for any dog receiving 2000 points.

## CHAPTER 12 – RULE CHANGES

### **Section 12.1 - Rule Changes**

Any rule changes will be in consultation with the AFA.

## CHAPTER 13 - INVESTIGATIONS

### Section 13.1 - Investigations

Investigations will be done in accordance with the Controlling Body's Constitution and Rules.

## Appendix A - Guidelines for Round Robin Competition

### Section A.1

Each team races every other team entered in their division an equal number of times.

### Section A.2

Each race shall have three or five heats or be the best three out of five heats.

### Section A.3

The following points are awarded:

- (i) 2 points to the winning team;
- (ii) 1 point for each team for tied or dead heats;
- (iii) 0 points to the losing team.

It is recommended that when the best three out of five format is used, that ties be re-run and no round robin points are awarded for the tied race. Places are determined by the number of points awarded to each team.

### Section A.4

If two or more teams earn the same number of points, one of the following tie breakers are to be used:

- (i) A head to head run off (normally two out of three);
- (ii) Results of the head to head competition during the course of the competition.

In the unlikely case that the teams tied during the course of the competition, then the team with the best-weighted average time shall be determined to be the winner. The weighted average time shall be the best two out of three races; best four out of six; best six out of nine and so on ...

### Section A.5

The ANKC recommends that a single or double elimination final conclude each round robin division competition.

**OFFICIAL FLYBALL ENTRY FORM**  
Under the Rules of the Member Body of the ANKC

Date: \_\_\_\_\_

Name of Affiliate Club: \_\_\_\_\_

Entry Fee: \_\_\_\_\_

Catalogue: Yes/No \_\_\_\_\_

**Team Information** Club: \_\_\_\_\_

Team Name: \_\_\_\_\_

Captain Box Loader: \_\_\_\_\_

Postal Address: Telephone: \_\_\_\_\_

Email: \_\_\_\_\_

**Seed Time will be taken from current "Team Rankings" 14 days prior to competition date. A declared seed time may be submitted, but may be at least one (1) second slower than ranking and be accompanied by a clear explanation for the change.**

Declared Seed Time (in seconds): Reason for Change: \_\_\_\_\_

**Break Out Penalties apply to all ANKC Sanctioned competitions.**  
*Any dog entered in an Controlling Body's Sanctioned competition without an ANKC Registered Number will result in forfeiture of all points and event placements for that team.*

**Declaration: All team members hereby apply to enter the foregoing exhibits in terms of an upon the conditions set out in the Controls Constitution and Rules by which they agree to be bound and they hereby certify to the correctness of the particulars endorsed hereon.**

**(1)** Dog's Name and Titles: \_\_\_\_\_

Breed: Date of Birth: Sex: \_\_\_\_\_

Registered Number: Jump Height: \_\_\_\_\_

Name of Exhibitor/Owner: Telephone: \_\_\_\_\_

Membership No: Signature: \_\_\_\_\_

**(2)** Dog's Name and Titles: \_\_\_\_\_

Breed: Date of Birth: Sex: \_\_\_\_\_

Registered Number: Jump Height: \_\_\_\_\_

Name of Exhibitor/Owner: Telephone: \_\_\_\_\_

Membership No: Signature: \_\_\_\_\_

**(3)** Dog's Name and Titles: \_\_\_\_\_

Breed: Date of Birth: Sex: \_\_\_\_\_

Registered Number: Jump Height: \_\_\_\_\_

Name of Exhibitor/Owner: Telephone: \_\_\_\_\_

Membership No: Signature: \_\_\_\_\_

**(4)** Dog's Name and Titles: \_\_\_\_\_

Breed: Date of Birth: Sex: \_\_\_\_\_

Registered Number: Jump Height: \_\_\_\_\_

Name of Exhibitor/Owner: Telephone: \_\_\_\_\_

Membership No: Signature: \_\_\_\_\_

**(5)** Dog's Name and Titles: \_\_\_\_\_

Breed: Date of Birth: Sex: \_\_\_\_\_

Registered Number: Jump Height: \_\_\_\_\_

Name of Exhibitor/Owner: Telephone: \_\_\_\_\_

Membership No: Signature: \_\_\_\_\_

**(6)** Dog's Name and Titles: \_\_\_\_\_

Breed: Date of Birth: Sex: \_\_\_\_\_

Registered Number: Jump Height: \_\_\_\_\_

Name of Exhibitor/Owner: Telephone: \_\_\_\_\_

Membership No: Signature: \_\_\_\_\_

<b>Competition:</b>		<b>Judge:</b>	
<b>Date:</b>		<b>Division:</b>	
<b>Team:</b>		<b>Seed Time:</b>	
<b>Captain:</b>		<b>Break Out Time:</b>	

	Dog's Name	CRN	Jump Height	Handler Name	Breed	Y D/H	R D/H	B D/H	Total Points
1									
2									
3									
4									
5									
6									

\*\*\*Please indicate four dogs for each heat – incorrect indication could result in no points being awarded\*\*\*

PLEASE DO NOT WRITE IN ANY GREYED AREA – THESE AREAS ARE TO BE USED BY THE COMPETITION ORGANISER ONLY

L	Heat	Versus	Dog	Time	M	4	Result	Any Use	Points
	1 of 3		1 2 3 4 5 6 _____		M	4	W L T _____		
	2 of 3		1 2 3 4 5 6 _____		M	4	W L T _____		
	3 of 3		1 2 3 4 5 6 _____		M	4	W L T _____		
	1 of 3		1 2 3 4 5 6 _____		M	4	W L T _____		
	2 of 3		1 2 3 4 5 6 _____		M	4	W L T _____		
	3 of 3		1 2 3 4 5 6 _____		M	4	W L T _____		
	1 of 3		1 2 3 4 5 6 _____		M	4	W L T _____		
	2 of 3		1 2 3 4 5 6 _____		M	4	W L T _____		
	3 of 3		1 2 3 4 5 6 _____		M	4	W L T _____		
	1 of 3		1 2 3 4 5 6 _____		M	4	W L T _____		
	2 of 3		1 2 3 4 5 6 _____		M	4	W L T _____		
	3 of 3		1 2 3 4 5 6 _____		M	4	W L T _____		
	1 of 3		1 2 3 4 5 6 _____		M	4	W L T _____		
	2 of 3		1 2 3 4 5 6 _____		M	4	W L T _____		
	3 of 3		1 2 3 4 5 6 _____		M	4	W L T _____		
	1 of 3		1 2 3 4 5 6 _____		M	4	W L T _____		
	2 of 3		1 2 3 4 5 6 _____		M	4	W L T _____		
	3 of 3		1 2 3 4 5 6 _____		M	4	W L T _____		
	1 of 3		1 2 3 4 5 6 _____		M	4	W L T _____		
	2 of 3		1 2 3 4 5 6 _____		M	4	W L T _____		
	3 of 3		1 2 3 4 5 6 _____		M	4	W L T _____		

<b>Place:</b>	1 <sup>st</sup>	2 <sup>nd</sup>	3 <sup>rd</sup>	4 <sup>th</sup>	5 <sup>th</sup>	6 <sup>th</sup>	<b>Best Time:</b>
<b>Judge:</b>							<b>AFA Rep:</b>

<b>Competition:</b>		<b>Judge:</b>	
---------------------	--	---------------	--

<b>Date:</b>		<b>Division:</b>	
<b>Team:</b>		<b>Seed Time:</b>	
<b>Captain:</b>		<b>Break Out Time:</b>	

	Dog's Name	CRN	Jump Height	Handler Name	Breed	Y D/H	R D/H	B D/H	Total Points
1									
2									
3									
4									
5									
6									

\*\*\*Please indicate four dogs for each heat – incorrect indication could result in no points being awarded\*\*\*

PLEASE DO NOT WRITE IN ANY GREYED AREA – THESE AREAS ARE TO BE USED BY THE COMPETITION ORGANISER ONLY

L	Heat	Versus	Dog	Time	M	4	Result	Any Use	Points
	1 of 5		1 2 3 4 5 6	_____	M	4	W L T		
	2 of 3		1 2 3 4 5 6	_____	M	4	W L T		
	3 of 3		1 2 3 4 5 6	_____	M	4	W L T		
	1 of 3		1 2 3 4 5 6	_____	M	4	W L T		
	2 of 3		1 2 3 4 5 6	_____	M	4	W L T		
	3 of 3		1 2 3 4 5 6	_____	M	4	W L T		
	1 of 3		1 2 3 4 5 6	_____	M	4	W L T		
	2 of 3		1 2 3 4 5 6	_____	M	4	W L T		
	3 of 3		1 2 3 4 5 6	_____	M	4	W L T		
	1 of 3		1 2 3 4 5 6	_____	M	4	W L T		
	2 of 3		1 2 3 4 5 6	_____	M	4	W L T		
	3 of 3		1 2 3 4 5 6	_____	M	4	W L T		
	1 of 3		1 2 3 4 5 6	_____	M	4	W L T		
	2 of 3		1 2 3 4 5 6	_____	M	4	W L T		
	3 of 3		1 2 3 4 5 6	_____	M	4	W L T		
	1 of 3		1 2 3 4 5 6	_____	M	4	W L T		
	2 of 3		1 2 3 4 5 6	_____	M	4	W L T		
	3 of 3		1 2 3 4 5 6	_____	M	4	W L T		
	1 of 3		1 2 3 4 5 6	_____	M	4	W L T		
	2 of 3		1 2 3 4 5 6	_____	M	4	W L T		
	3 of 3		1 2 3 4 5 6	_____	M	4	W L T		

<b>Place:</b>	1 <sup>st</sup>	2 <sup>nd</sup>	3 <sup>rd</sup>	4 <sup>th</sup>	5 <sup>th</sup>	6 <sup>th</sup>	<b>Best Time:</b>
<b>Judge:</b>							<b>AFA Rep:</b>

**Appendix C - Typical Ring Set**

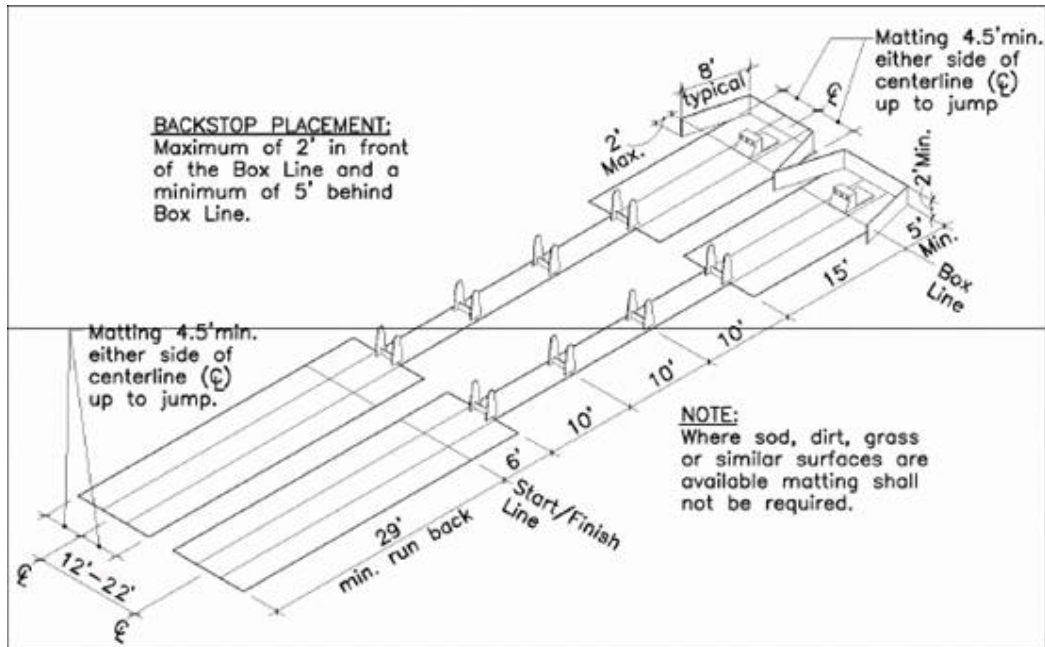

## Appendix D - Judges Guidelines (Condensed)

### Section D.1 - In general

- (a) Give a warning if:
  - (i) it is not a clear violation; or
  - (ii) if the other team has completed the race and is a clear winner.
- (b) Flags should be held up sufficiently so the team has an opportunity to note the penalty.
- (c) Judges and/or Stewards are not obligated to advise teams when a dog is to run again, nor are they obligated to explain a decision.

### Section D.2 - When to stop a race (indicate with a whistle)

- (a) For the first false start (in any one heat) Judge to indicate with a signal.
- (b) For interference.
- (c) If a dog fouls in the ring.
- (d) If the box loader indicates the box has malfunctioned.
- (e) If in the Judge's opinion there is a safety hazard.
- (f) Aggression

### Section D.3 - When to restart a race

- (a) For a false start (first time only for any one heat).
- (b) If the box malfunctions (first time only for any one heat).
- (c) If the Judge stopped the race because there was an injury to a dog or handler
- (d) After replacement of a broken board if the Judge stopped the heat for safety reasons.

### Section D.4 - When a team would forfeit the heat

- (a) For the second time a box malfunctioned in any one heat or if the Judge determines the box did not malfunction.
- (b) If a dog fouls in the ring.
- (c) Interference.
- (d) The second time a handler enters the ring not wearing their ANKC Registered Dog Number.

### **Section D.5 - When dogs must race again (indicate with a signal)**

- (a) For an illegal pass or for a second false start in any one heat.
- (b) If the dog:
  - (i) misses one or more jumps;
  - (ii) fails to carry the ball over the start/finish line;
  - (iii) takes the ball from the cup;
  - (iv) does not trigger the box.
- (c) If the dog is aided by other than verbal assistance (i.e. by a spectator, box loader or a handler). The dog is not to be penalised for retrieving a ball from out of bounds/play unless aided.
- (d) If the handler crosses the start/finish line (other than to retrieve a loose ball or set up a knocked down jump).

### **Section D.6 - Judge's Responsibilities**

- (a) Inspect boxes and the ring set-up prior to racing.
- (b) Measure dogs under 508mm (20 inches).
- (c) Check with each Steward and team prior to the start of each race.
- (d) Start and stop the races. The race is not over until the Judge declares a winner.
- (e) Observe handlers for possible violation (bouncing tennis balls or otherwise distracting the other teams).
- (f) Get into position to observe the finish without distracting either team.
- (g) Confer with the all Stewards and timekeepers prior to the start and following each heat.
- (h) Declare a winner and indicate to the teams and spectators who is the winner.
- (i) Notify the announcer of the outcome of the heat.
- (j) Check the time sheets following each race.
- (k) Sign the time sheets following the competition.

### **Section D.7 - Timekeeper's Responsibilities**

- (a) Record which dogs participate in every heat using the ANKC Time Sheet.
- (b) Operate the EJS for the duration of each heat.
- (c) Press the manual foul for their assigned lane when a dog fouls.
  - (i) A dog misses a jump.
  - (ii) A dog does not carry the current ball across the start/finish line in its mouth,
  - (iii) A dog does not trigger the box,
  - (iv) A dog fouls in the ring,
  - (v) If a handler crosses the start/finish line during a heat (other than to set up a knocked down jump or to retrieve a loose ball) or other role violations for which a dog must run again.
  - (vi) Record any violations on the team's timesheet as per the Judge's instructions.
  - (vii) Record on the timesheet the recalculated time on the time sheet given by the EJS after the EJS has declared the winner and record the winner.
  - (viii) Mark when a manual time has been used due to EJS failure.

### **Section D.8 - Line Steward's Responsibilities**

- (a) Record times on a stop watch for each heat run in case of EJS failure.
- (b) Signal with a flag when their assigned lane has fouled
  - (i) A dog misses a jump;
  - (ii) A dog does not carry the current ball across the start/finish line in its mouth;
  - (iii) A dog does not trigger the box;
  - (iv) A dog fouls in the ring, if a handler crosses the start/finish line during a heat (other than to set up a knocked down jump or to retrieve a loose ball) or other role violations for which a dog must run again.

- (c) Confer with the Judge following each heat to determine the winning team.
- (d) Manual timing only:
  - (i) Observe for false starts and illegal passes in assigned lane.
  - (ii) Stop the race for a false start (first time).
  - (iii) Indicate with a flag a second false start (same heat), illegal pass, or if the handler crosses the start/finish line.

**Section D.9 - Box Steward's Responsibilities**

- (a) Observe that the box loader or spectators do not assist the dog racing.
- (b) Signal to the Judge for box a malfunction (box loader to indicate to the box steward if the box malfunctioned).
- (c) Signal by raising their flag when a dog:
  - (i) Fouls in the ring;
  - (ii) Misses a jump;
  - (iii) Does not trigger the box, or the box loader or spectator assists the dog in any manner that is not provided for in the Rules.

**Section D.10 - Inbound Steward's Responsibilities**

Watch for:

- (a) Throwing of motivators or ball
- (b) Other distraction incidents
- (c) Aggressive incidents involving dogs and/or handlers
- (d) Incidents of Interference
- (e) Fouling in the ring
- (f) Handler indiscretions

**Appendix E – Racing Schedules**

**Round Robin Format:**

- 3 Team** - Allow 30 Minutes for races
- 4 Team** - Allow 1 Hour for races
- 5 Team** - Allow 1 Hour and 20 Minutes for races
- 6 Team** - Allow 2 Hours and 10 Minutes for races
- 7 Team** - Allow 3 Hours for races
- 8 Team** - Allow 4 Hours for races
- 9 Team** - Allow 5 Hours and 10 Minutes for races

**Double Elimination Format:**

- 3 Team** - Allow 50 Minutes for races
- 4 Team** - Allow 1 Hour and 10 Minutes for races
- 5 Team** - Allow 1 Hour and 30 Minutes for races
- 6 Team** - Allow 1 Hours and 50 Minutes for races
- 7 Team** - Allow 2 Hours and 20 Minutes for races
- 8 Team** - Allow 2 Hours and 30 Minutes for races
- 9 Team** - Allow 2 Hours and 50 Minutes for races
- 10 Team** - Allow 3 Hours and 10 Minutes for races
- 11 Team** - Allow 3 Hours and 30 Minutes for races
- 12 Team** - Allow 3 Hours and 50 Minutes for races
- 13 Team** - Allow 4 Hours and 10 Minutes for races
- 14 Team** - Allow 4 Hours and 30 Minutes for races
- 15 Team** - Allow 4 Hours and 50 Minutes for races

**ROUND ROBIN RACE SCHEDULES**

**3 Team Round Robin**

Race 1	3	vs	1
Race 2	2	vs	3
Race 3	1	vs	2

**Allow 30 Minutes for Races**

**4 Team Round Robin**

Race 1	4	vs	1
Race 2	2	vs	3
Race 3	1	vs	3
Race 4	4	vs	2
Race 5	3	vs	4
Race 6	1	vs	2

**Allow 1 Hour for Races**

**5 Team Round Robin**

Race 1	5	vs	2
Race 2	4	vs	1
Race 3	3	vs	5
Race 4	2	vs	4
Race 5	1	vs	3
Race 6	4	vs	5
Race 7	2	vs	3
Race 8	5	vs	1
Race 9	3	vs	4
Race 10	1	vs	2

**Allow 1 Hour and 20 Minutes  
for Races**

**6 Team Round Robin**

Race 1	2	vs	3
Race 2	6	vs	1
Race 3	4	vs	5
Race 4	3	vs	6
Race 5	4	vs	2
Race 6	5	vs	1
Race 7	2	vs	6
Race 8	1	vs	4
Race 9	5	vs	3
Race 10	6	vs	4
Race 11	2	vs	5
Race 12	3	vs	1
Race 13	5	vs	6
Race 14	4	vs	3
Race 15	1	vs	2

**Allow 2 Hours and 10  
Minutes for Races**

**7 Team Round Robin**

Race 1	1	vs	4
Race 2	2	vs	5
Race 3	3	vs	6
Race 4	4	vs	7
Race 5	5	vs	1
Race 6	6	vs	2
Race 7	7	vs	3

Race 8	1	vs	3
Race 9	5	vs	7
Race 10	2	vs	4
Race 11	6	vs	1
Race 12	3	vs	5
Race 13	7	vs	2
Race 14	4	vs	6
Race 15	7	vs	1
Race 16	2	vs	3
Race 17	4	vs	5
Race 18	6	vs	7
Race 19	3	vs	4
Race 20	5	vs	6
Race 21	1	vs	2

**Allow 3 Hours for Races**

**8 Team Round Robin**

Race 1	4	vs	8
Race 2	3	vs	7
Race 3	2	vs	6
Race 4	1	vs	5
Race 5	6	vs	1
Race 6	8	vs	3
Race 7	2	vs	5
Race 8	4	vs	7
Race 9	3	vs	6
Race 10	5	vs	8
Race 11	7	vs	2
Race 12	1	vs	4
Race 13	8	vs	2
Race 14	4	vs	6
Race 15	7	vs	1
Race 16	3	vs	5
Race 17	6	vs	8
Race 18	2	vs	4
Race 19	5	vs	7
Race 20	1	vs	3
Race 21	8	vs	1
Race 22	6	vs	7
Race 23	4	vs	5
Race 24	2	vs	3
Race 25	7	vs	8
Race 26	5	vs	5
Race 27	3	vs	4
Race 28	1	vs	2

**Allow 4 Hours for Races**

**9 Team Round Robin**

Race 1	1	vs	9
Race 2	5	vs	7
Race 3	4	vs	8
Race 4	3	vs	6
Race 5	7	vs	9
Race 6	8	vs	2
Race 7	5	vs	3
Race 8	6	vs	1
Race 9	2	vs	4
Race 10	9	vs	5
Race 11	6	vs	8
Race 12	1	vs	7
Race 13	3	vs	2
Race 14	5	vs	4
Race 15	8	vs	1
Race 16	6	vs	7
Race 17	2	vs	9
Race 18	4	vs	3
Race 19	2	vs	7
Race 20	1	vs	5
Race 21	3	vs	9
Race 22	4	vs	6
Race 23	8	vs	9
Race 24	7	vs	3
Race 25	4	vs	1
Race 26	6	vs	2
Race 27	5	vs	8
Race 28	6	vs	9
Race 29	7	vs	4
Race 30	5	vs	2
Race 31	1	vs	3
Race 32	9	vs	4
Race 33	8	vs	7
Race 34	5	vs	6
Race 35	3	vs	8
Race 36	2	vs	1

**3 TEAM DOUBLE ELIMINATION**

Allow 40 Minutes For Racing  
Team On Top On The Left

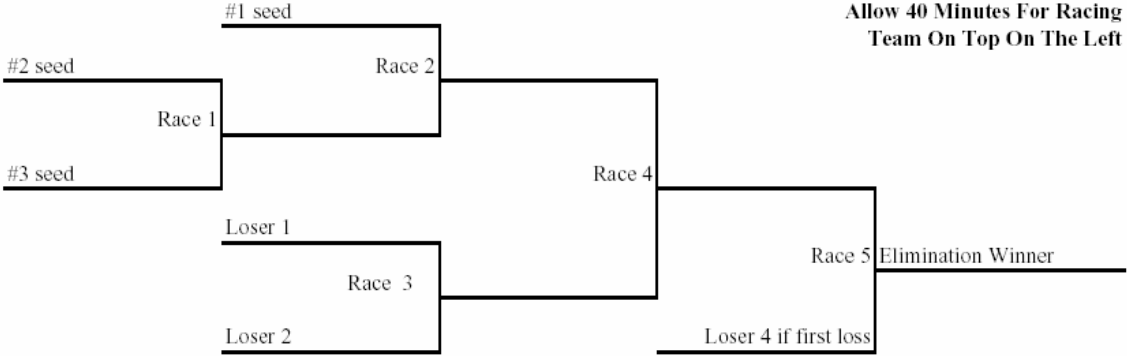

**4 TEAM DOUBLE ELIMINATION**

Allow 50 Minutes For Racing  
Team on Top On The Left

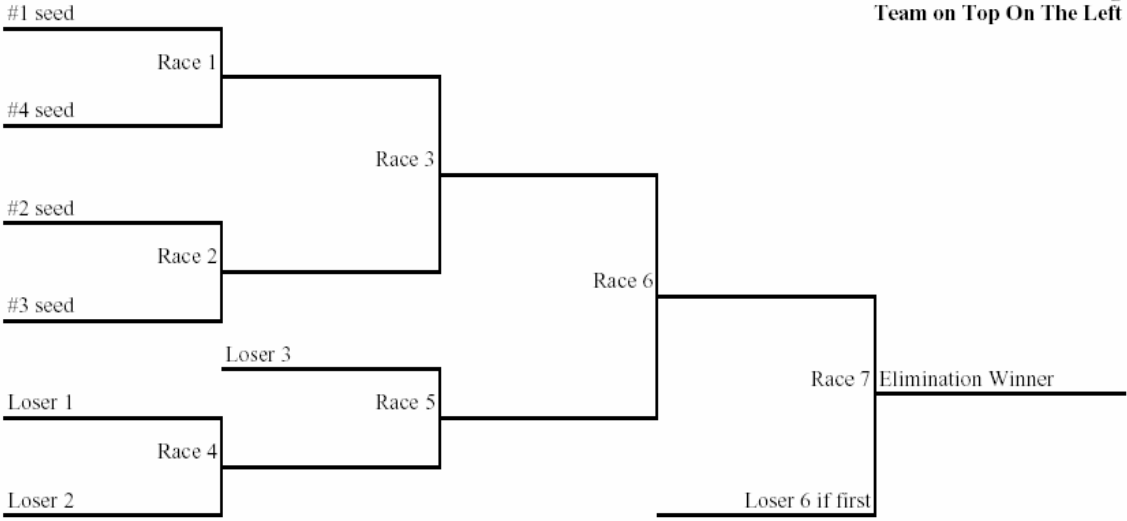

# 5 TEAM DOUBLE ELIMINATION

Allow 1 hr And 0 Minutes

Team On Top On The Left

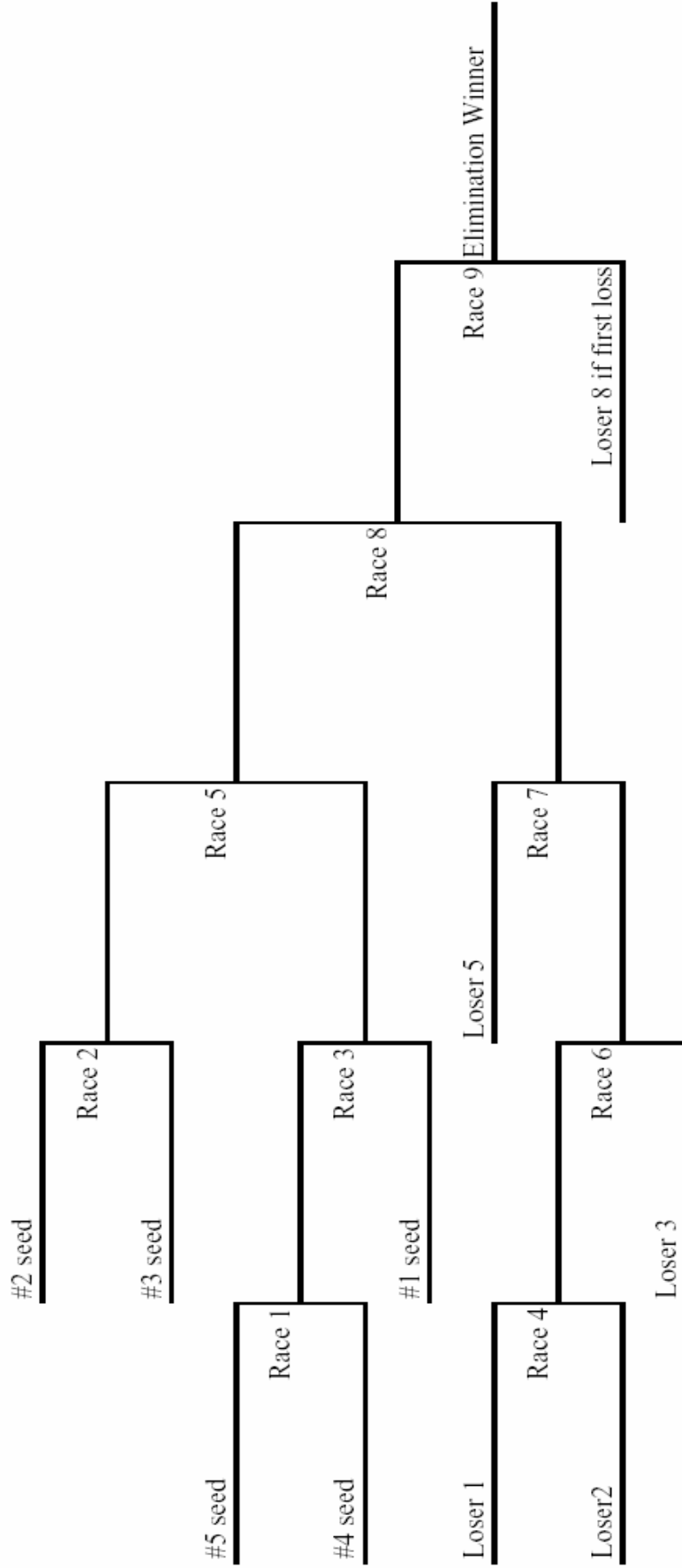

# 6 TEAM DOUBLE ELIMINATION

Allow 1 hr And 0 Minutes For Racing  
Team On Top On The Left

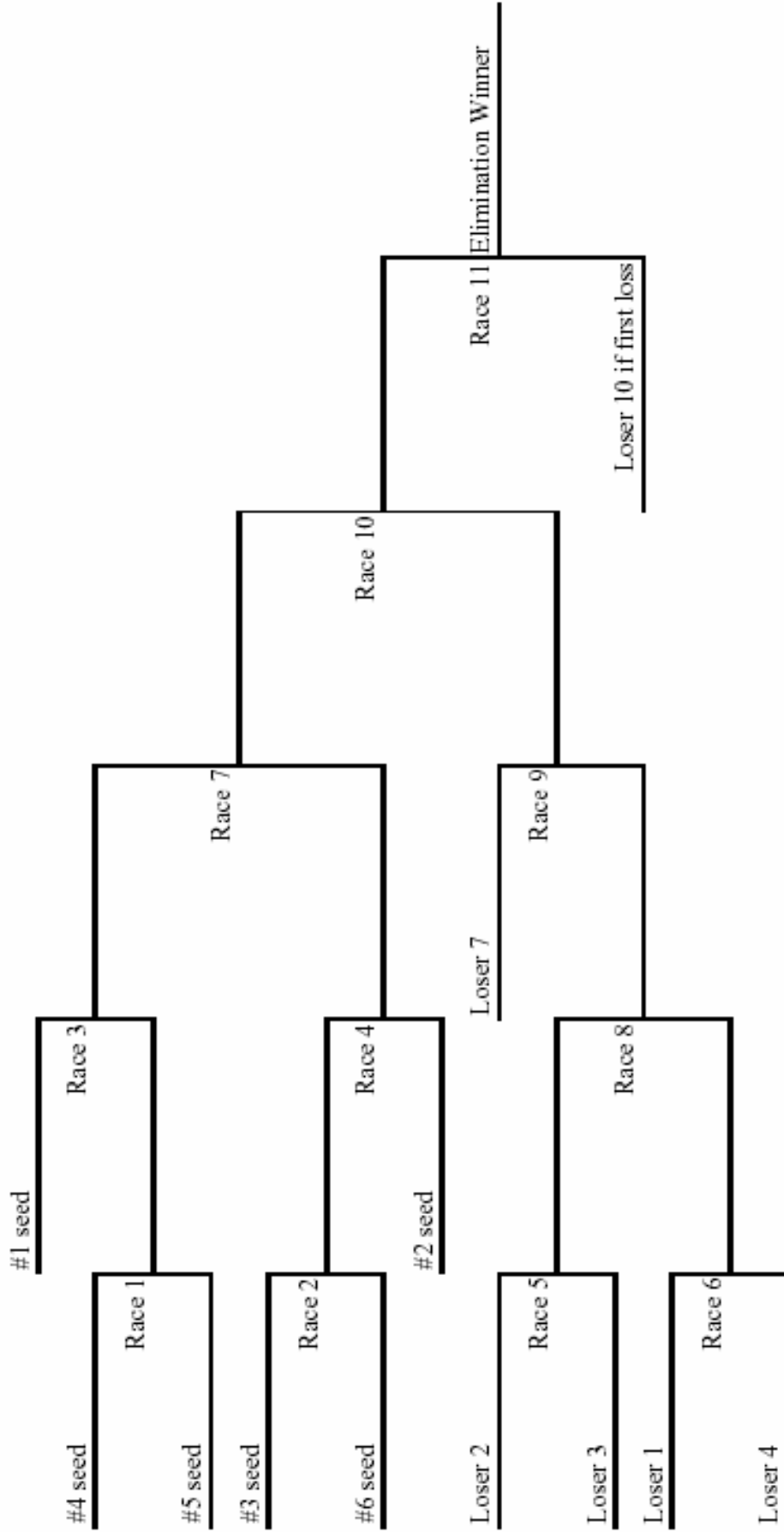

# 7 TEAM DOUBLE ELIMINATION

Allow 1 hr And 5 Minutes For Racing  
Team On Top On The Left

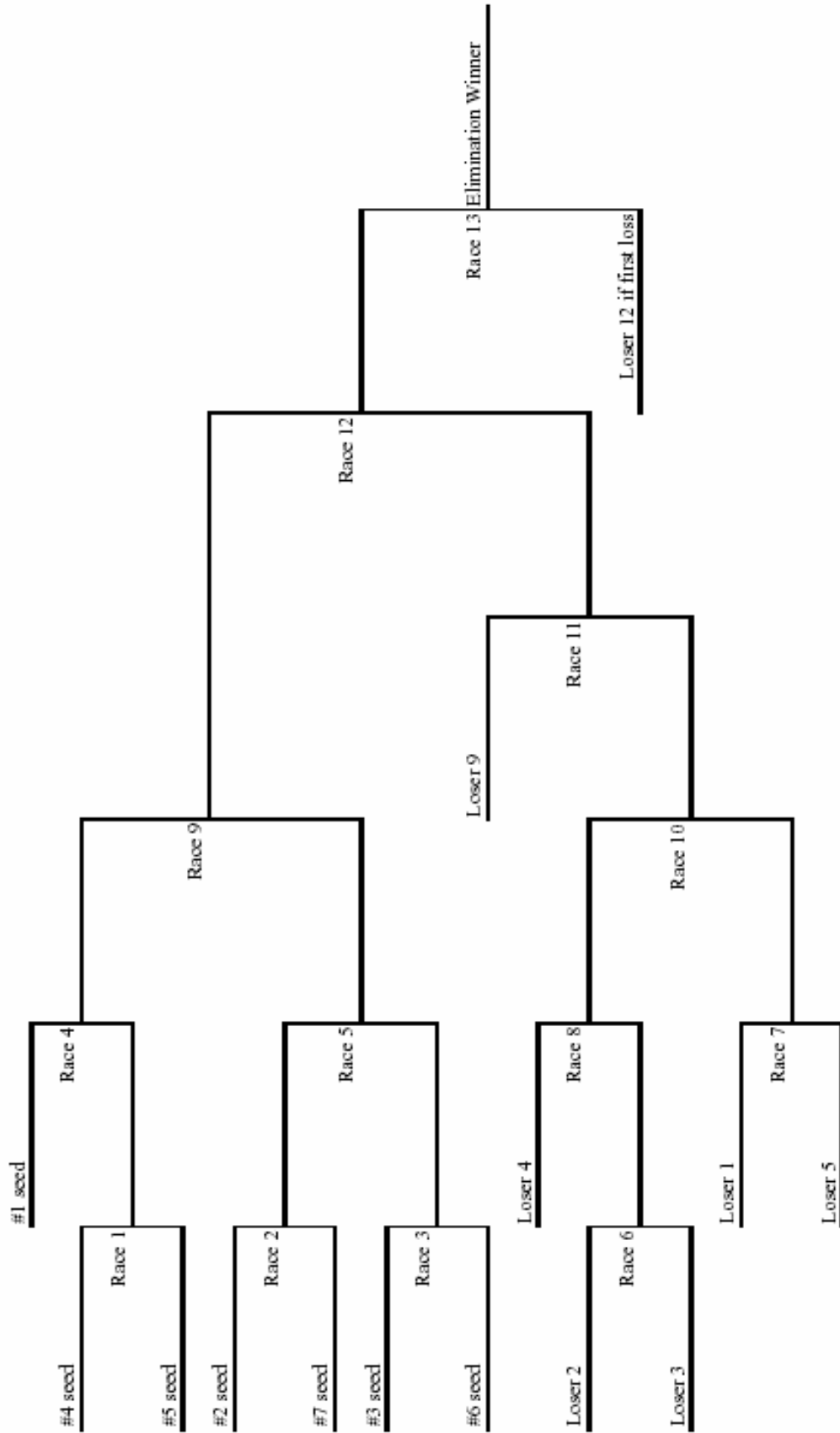

# 8 TEAM DOUBLE ELIMINATION

Allow 2 Hours for Racing

Team on top on the left

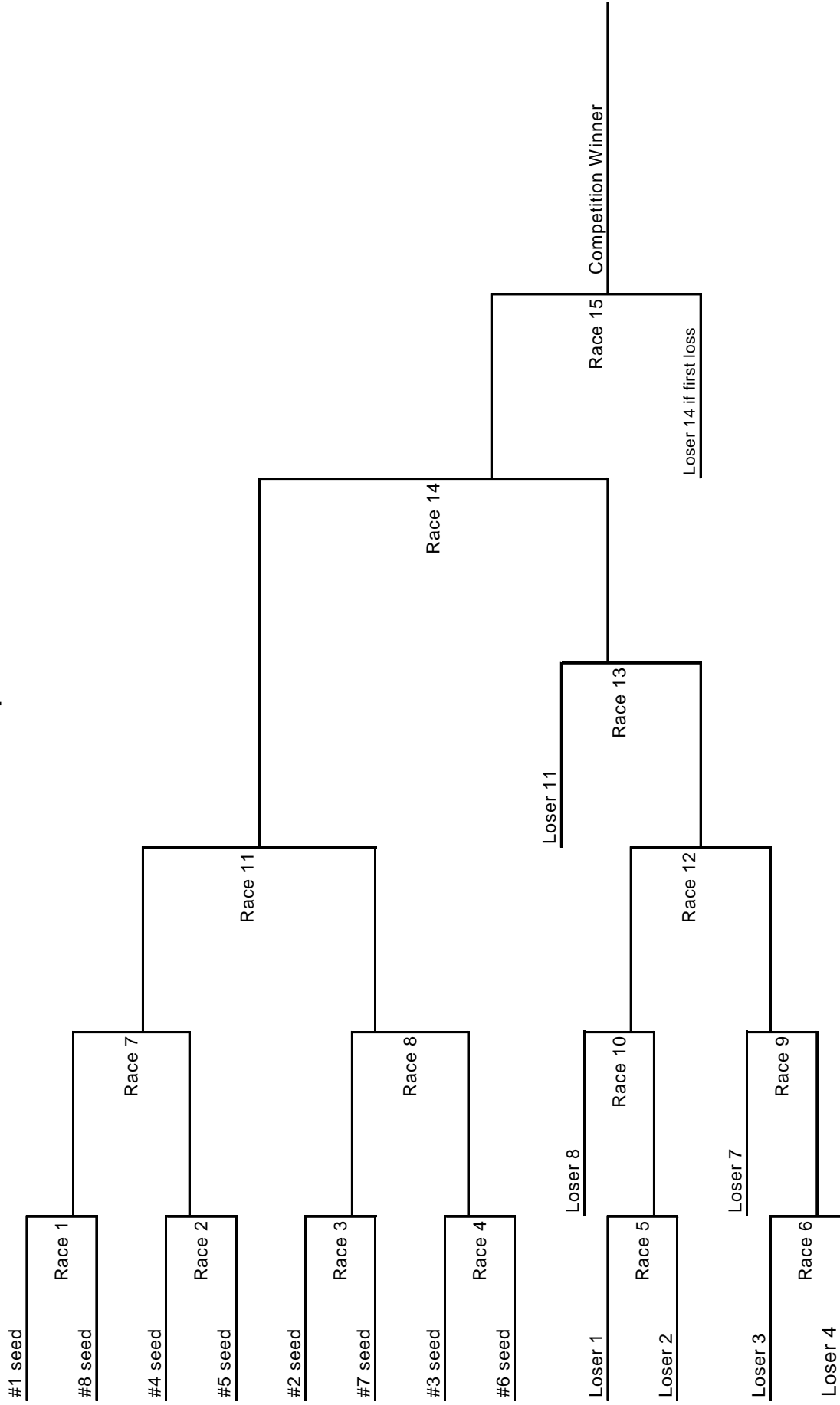

**9 TEAM DOUBLE ELIMINATION**  
 Allow 2 Hours and 20 Minutes for Racing  
 Team on top on the left

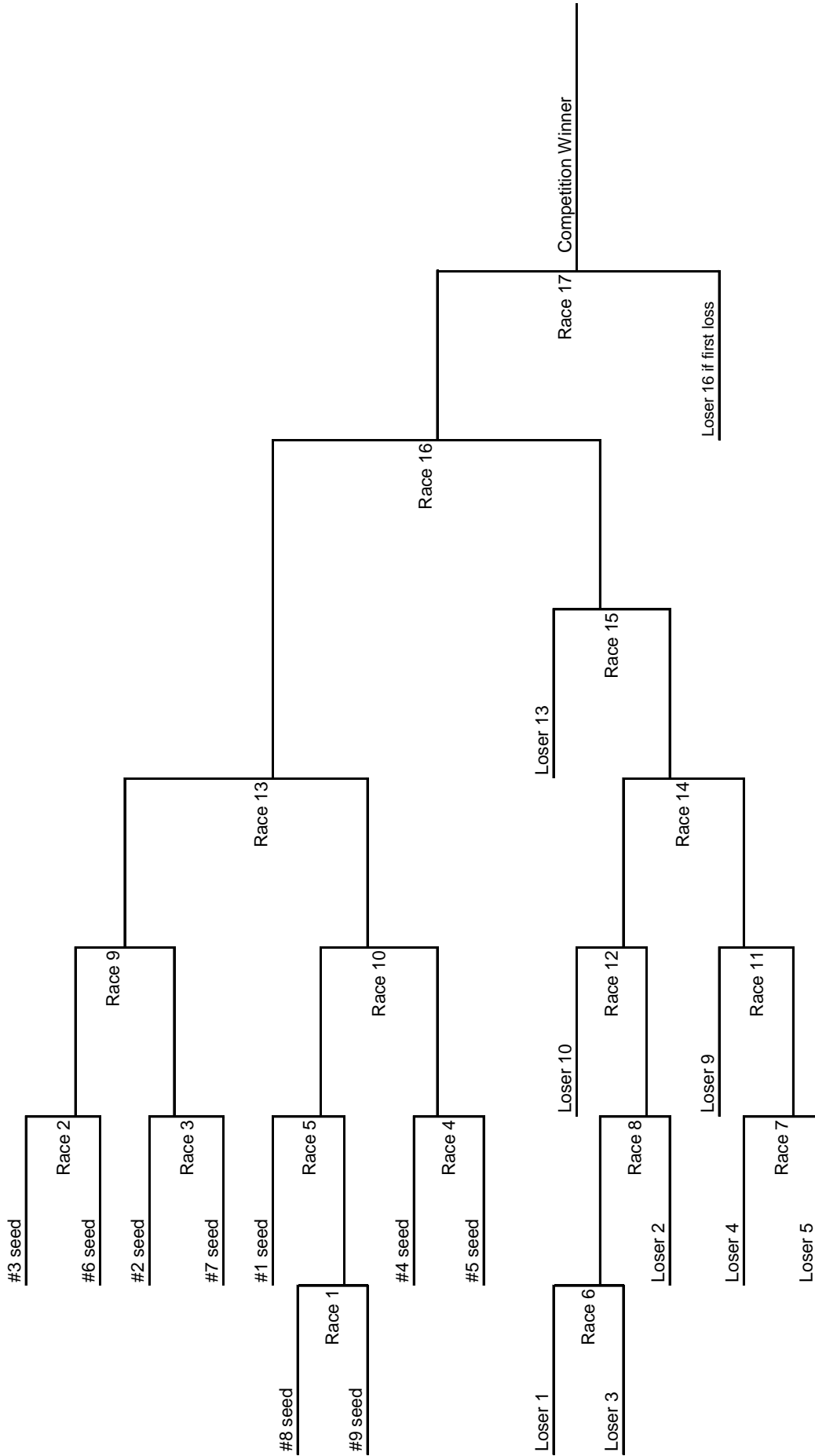

**10 TEAM DOUBLE ELIMINATION**  
 Allow 2 Hours and 40 Minutes for Racing  
 Team on top on the left

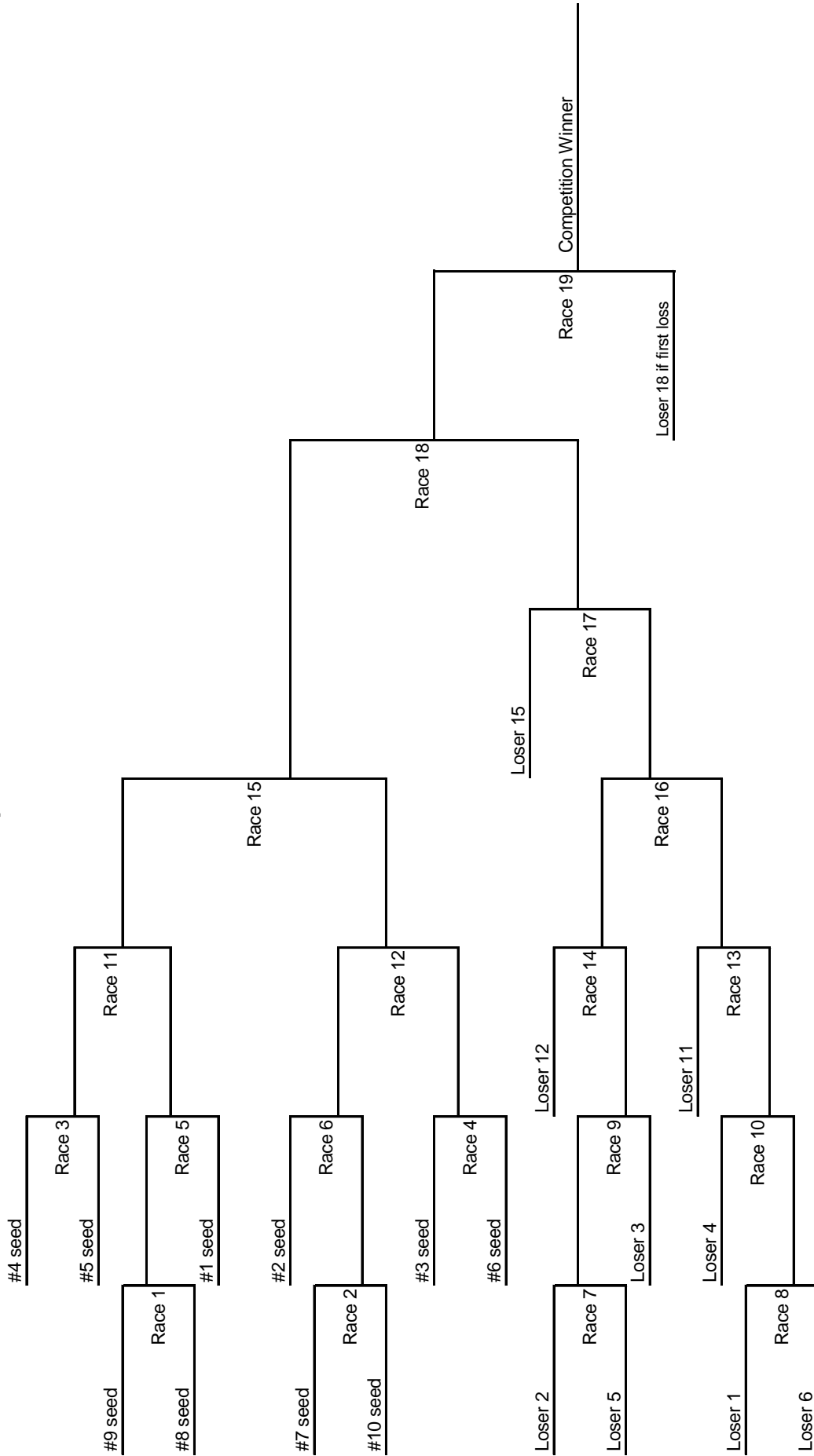

# 11 TEAM DOUBLE ELIMINATION

Allow 3 Hours for Racing

Team on top on the left

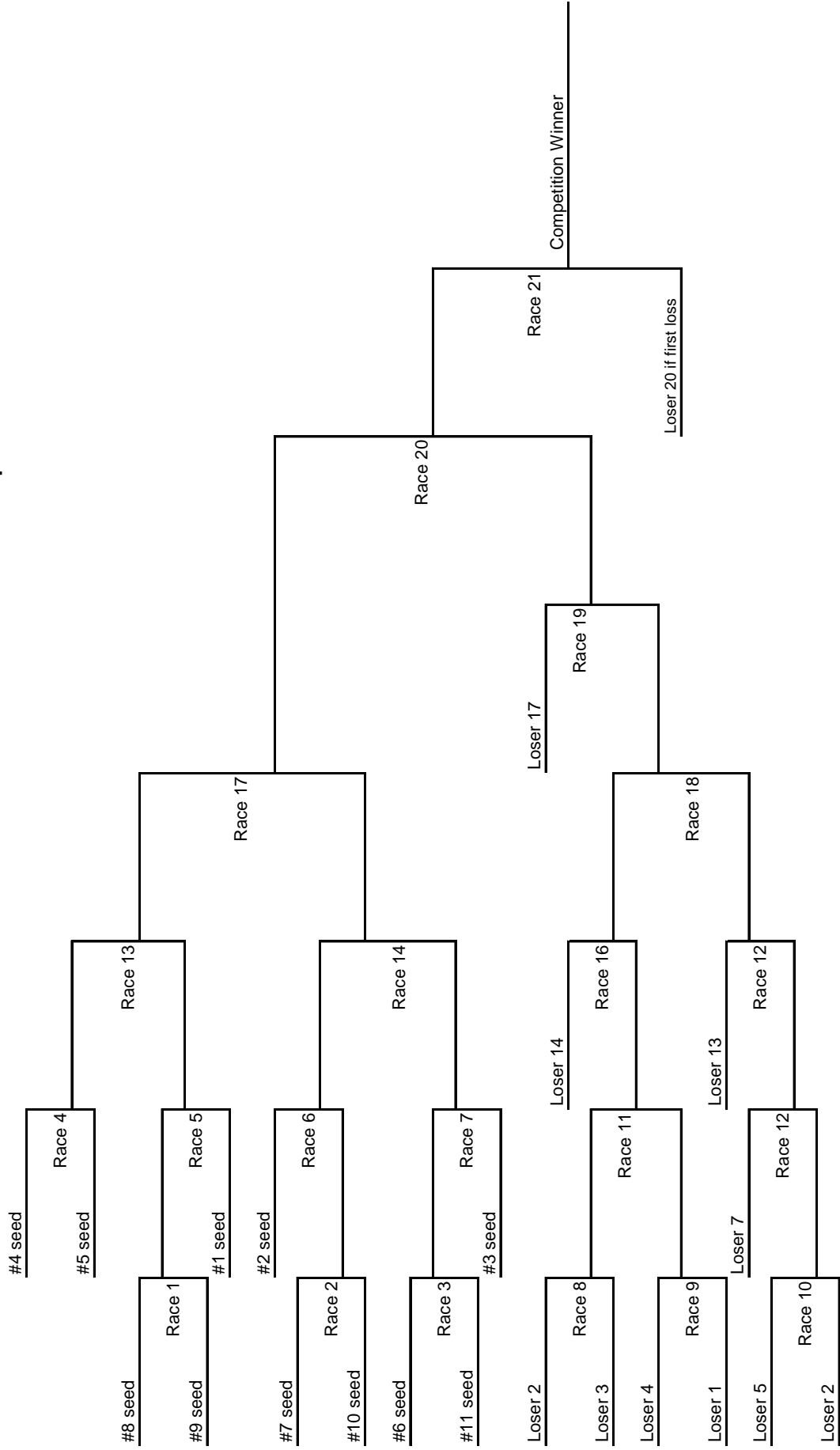

**12 TEAM DOUBLE ELIMINATION**  
 Allow 3 Hours and 10 Minutes for Racing  
 Team on top on the left

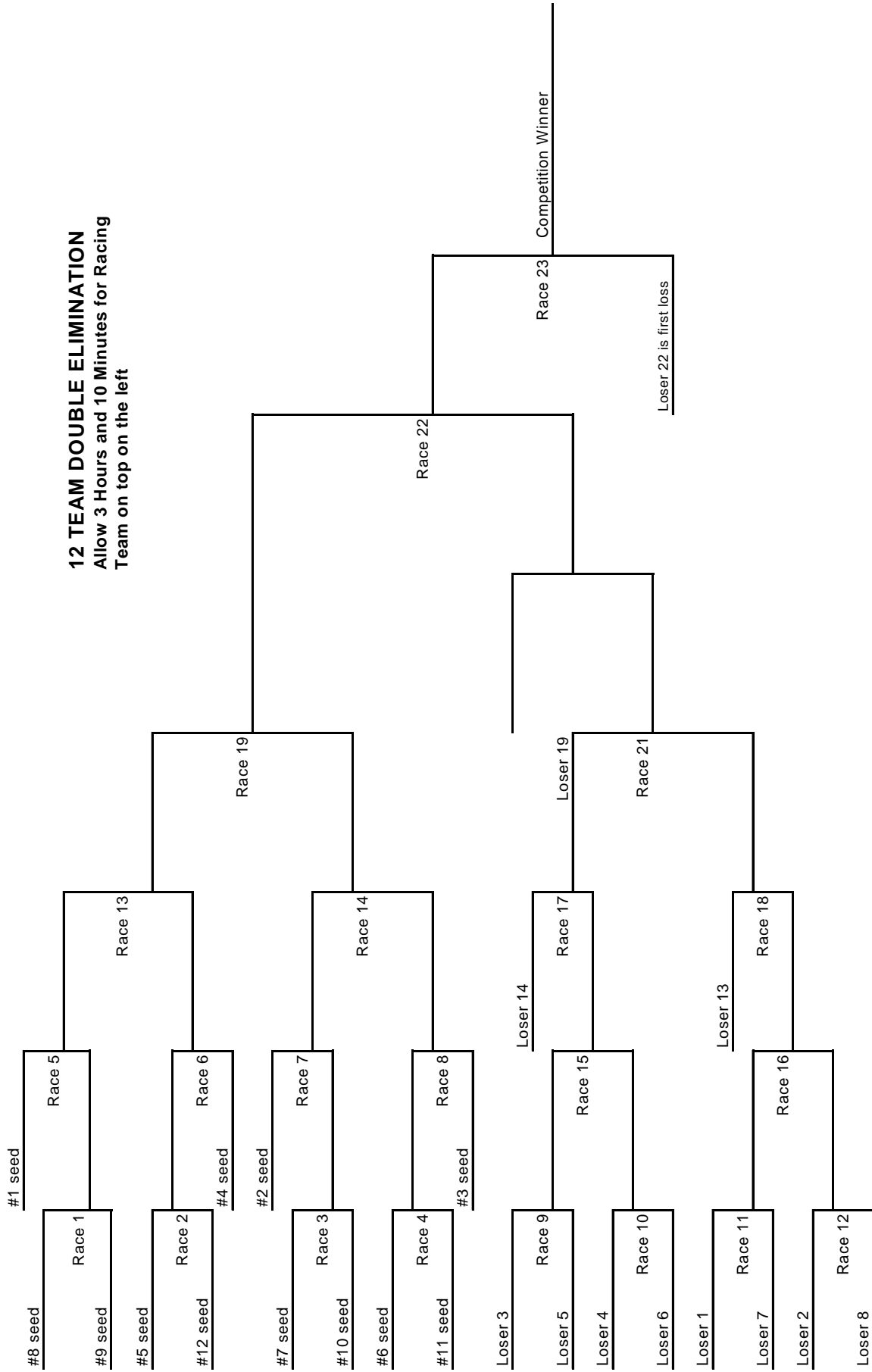

**13 TEAM DOUBLE ELIMINATION**  
 Allow 3 Hours and 30 Minutes for Racing  
 Team on top on the left

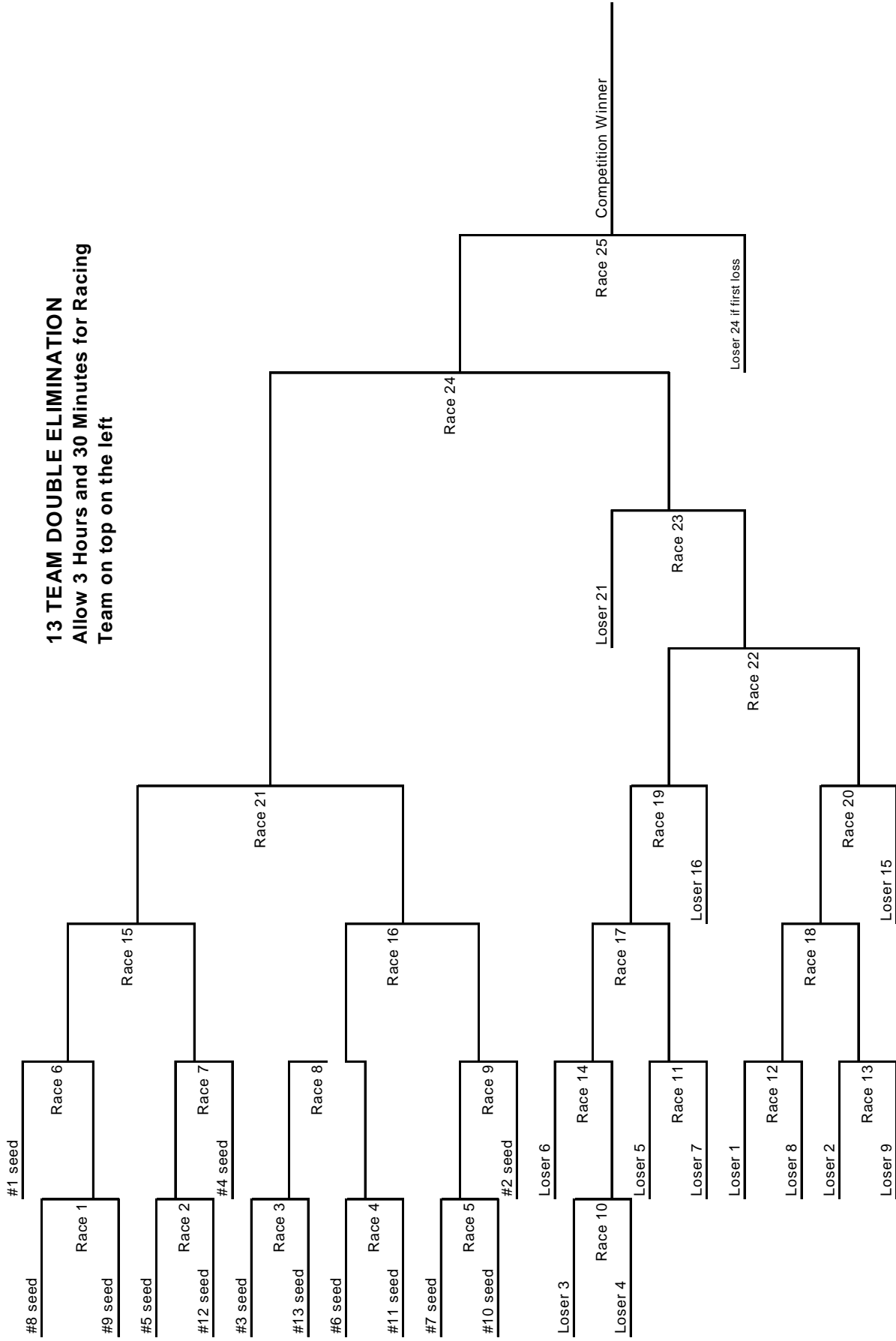

**14 TEAM DOUBLE ELIMINATION**  
 Allow 3 Hours and 45 Minutes for Racing  
 Team on top on the left

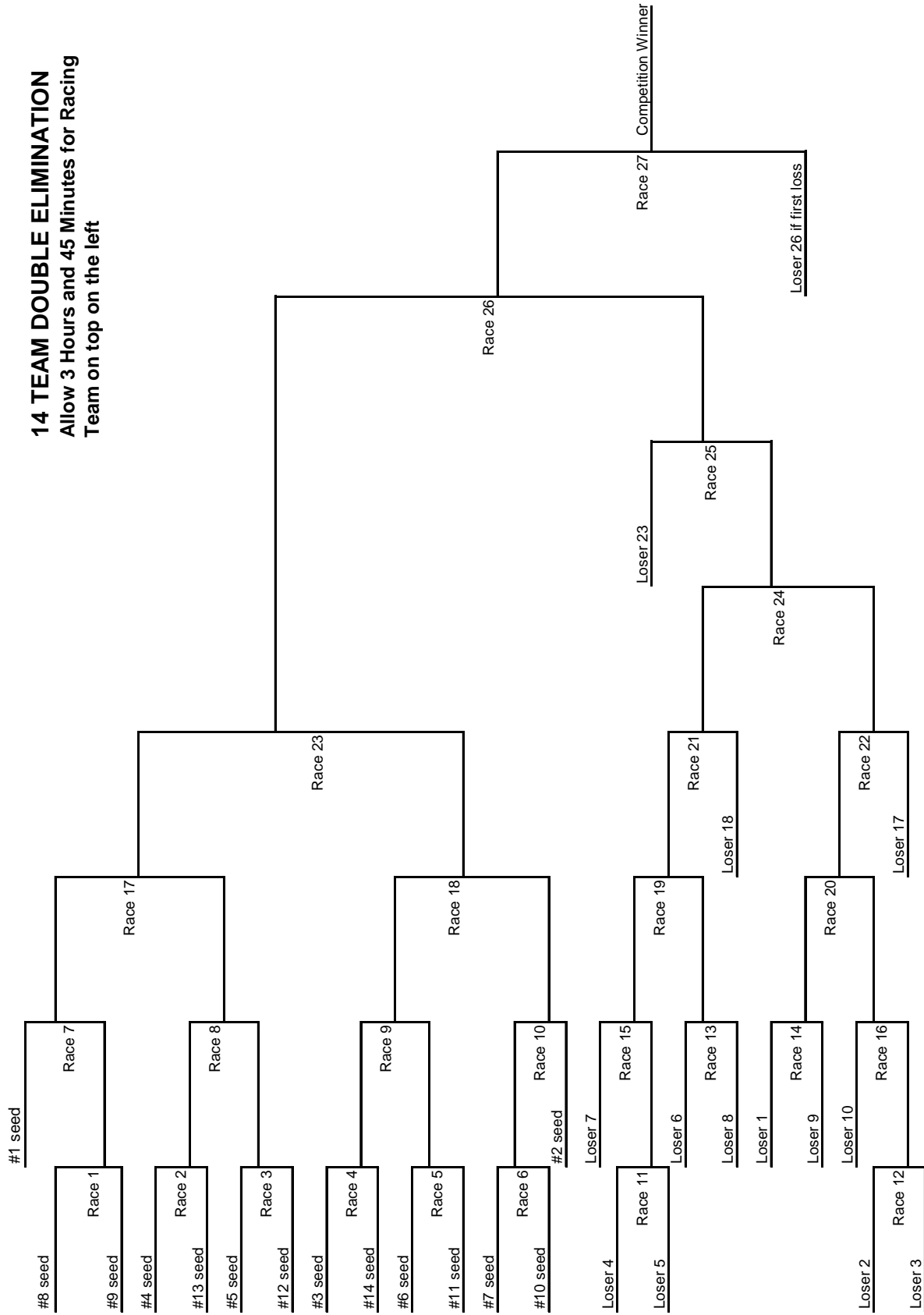



**16 TEAM DBL ELIMINATION**  
 Allow 4 Hours and 20 Minutes for Racing  
 Team on top on the left

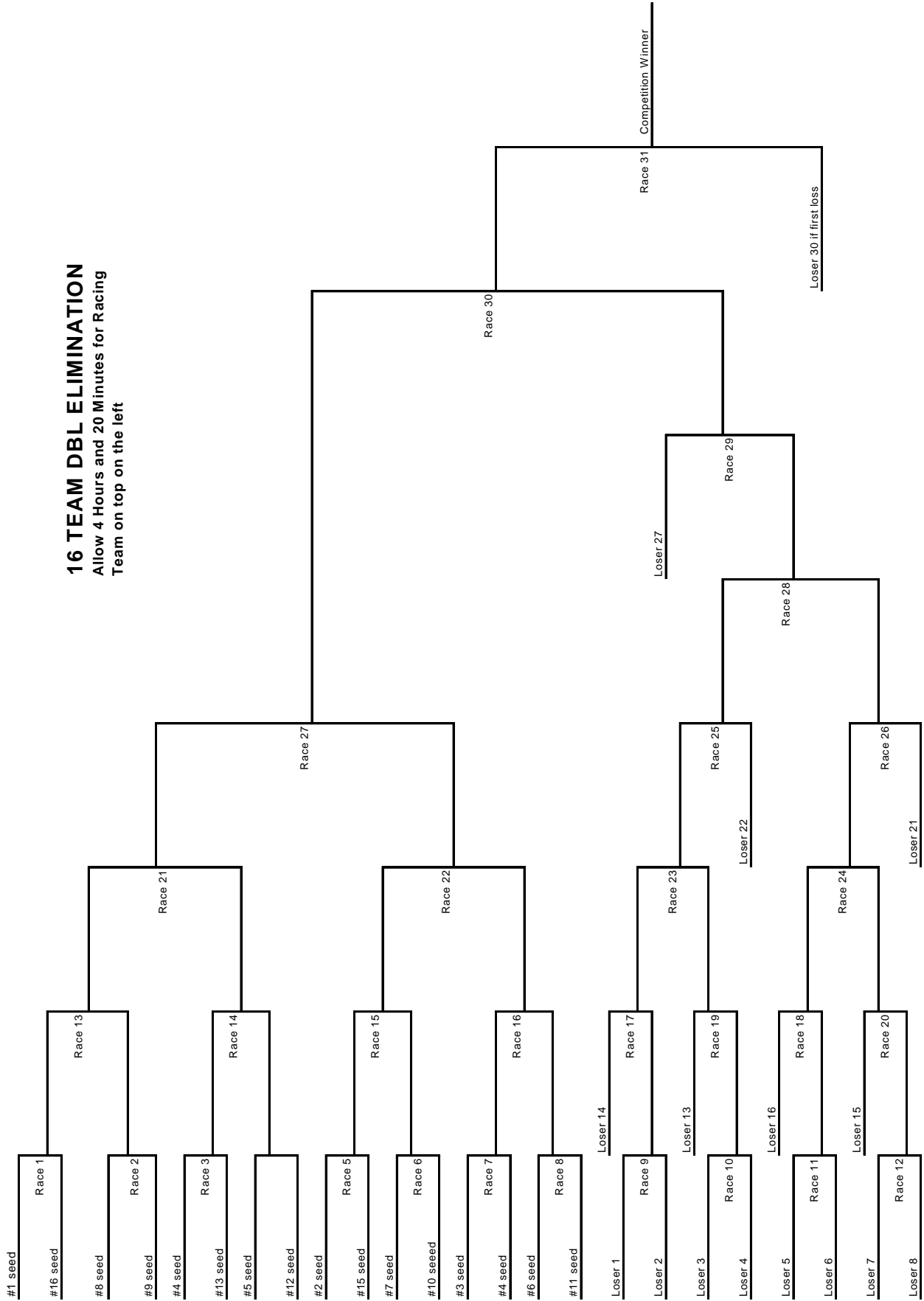



### 8 Team Single Elimination

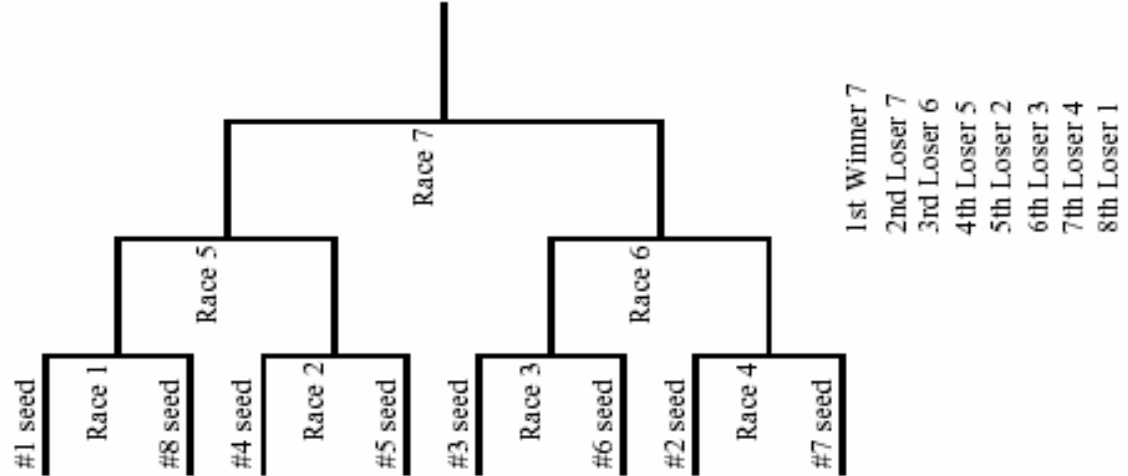

### 9 Team Single Elimination

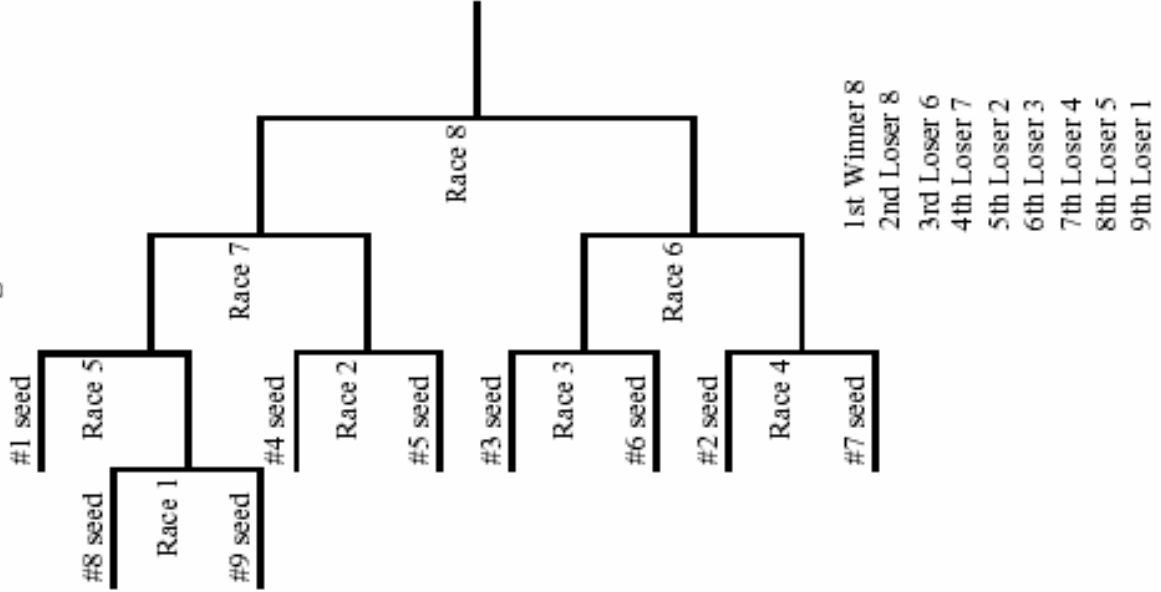

### 10 Team Single Elimination

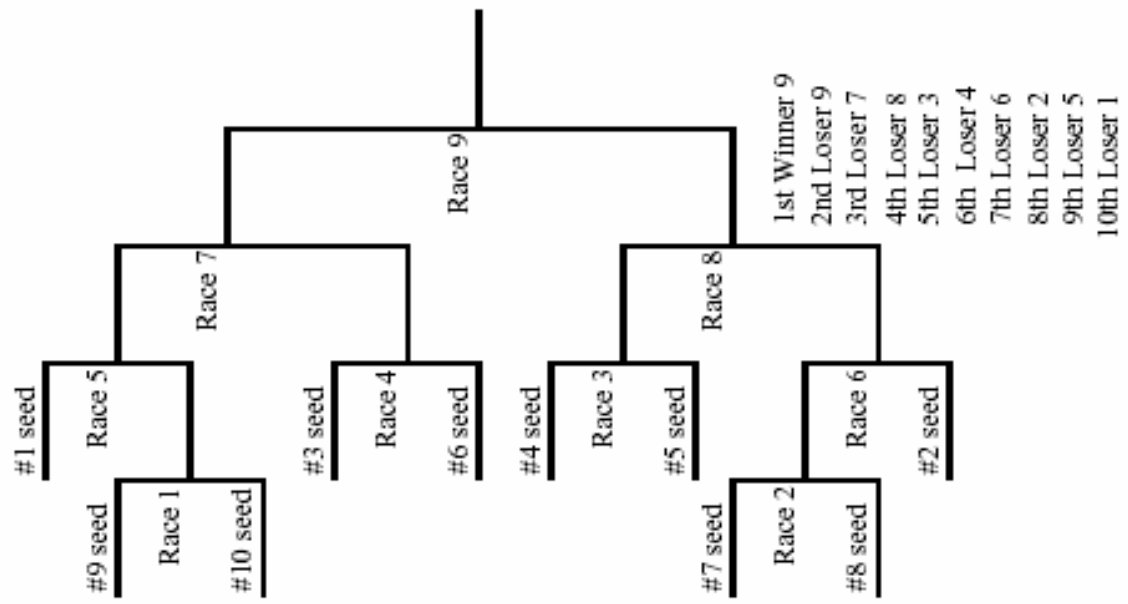

**Section E.1 - Provisional Judges Training**

**ANKC Rules - Chapter 10 – Judges**

- (a) Persons interested in becoming an approved ANKC Judge must complete successfully the Provisional Judges Training Program.
- (b) The minimum age for Judges, Stewards and Timekeepers is 18 years of age.

**Criteria to be met before an application will be considered by the Controlling Body:**

- Applicant must be 18 years or over.
- Applicant must be a full financial member of the Controlling Body for a minimum of 2 years.
- Applicant must have been involved in Flyball for a minimum of 2 years.
- Application must be made to the Controlling Body in writing as per the above criteria.
- Provisional Judges Training must be completed within a 12 months period after passing the written Judges exam.

**STEP 1 - Judges Written Exam:**

Before any provisional training can begin the aspiring Judge must complete the Judges exam and pass. The exam is designed to cover as many aspects of the ANKC Flyball Rules.

All written exam papers shall consist of short answer questions and/or multi choice questions only.

- (1) Should an aspirant request an oral exam, the questions shall remain the same, but will be read to the aspirant by an approved independent person.
- (2) The aspirant may write the answers or dictate the answers to the reader, who will then record the answers as dictated. Oral papers will be marked as for written papers.
- (3) There shall be two independent persons appointed to mark the papers. For multi choice questions one person only is required to mark the papers.
- (4) All written exams shall require an 80% pass mark.

**Only after completion and passing of the Judges written exam are Provisional Judges allowed to proceed to Step 2. Notification of approval to proceed will be sent in writing by the Controlling Body.**

**STEP 2 - Practical Examination:**

The ANKC Supervisory Judge will be appointed to supervise your provisional training by the Controlling Body. This Judge will have completed the provisional training themselves, with a sound knowledge of judging and Flyball and have judged at a minimum of twenty (20) competitions.

**Stewarding to be done by each Provisional Judge:**

Inbound Steward for a minimum of twenty (20) races. You are required to fill out the official form provided. The official form must be signed off by the ANKC Judge supervising your training at that competition and the Controlling Body Representative on the day. The ANKC Supervisory Judge will be in the ring next to you for questions and guidance at all times. All forms must be given to the Controlling Body Representative at the end of the competition, to be forwarded to the Controlling Body.

Box Steward for a minimum of twenty (20) races. You are required to fill out the official form provided. The official form must be signed off by the ANKC Judge supervising your training at that competition and the Controlling Body Representative on the day. The ANKC Supervisory Judge will be in the ring next to you for questions and guidance at all times. All forms must be given to the Controlling Body Representative at the end of the competition, to be forwarded to the Controlling Body.

Line Steward for a minimum of twenty (20) races. You are required to fill out the official form provided. The official form must be signed off by the ANKC Judge supervising your training at that competition and the Controlling Body Representative on the day. The ANKC Supervisory Judge will be in the ring next to you for questions and guidance at all times. All forms must be given to the Controlling Body Representative at the end of the competition, to be forwarded to the Controlling Body.

Time keep for a minimum of thirty (30) races to learn the correct procedure for the timing system. They must sit on the timing table with an experienced ANKC Supervisory Judge and learn how to track heat numbers etc and understand the time keeping and how the timing system works. The ANKC Supervisory Judge will be next to you for questions and guidance at all times. You are required to fill out the official form provided. The official form must be signed off by the ANKC Supervisory Judge and the Controlling Body Representative on the day. All forms must be given to the Controlling Body Representative at the end of the competition, to be forwarded to the Controlling Body.

**Assisting in the ring set up: (this may be done at every provisional competition)**

You must assist in the set up of the ring and learn how to square off the box end to be able to lay the two lanes out in a uniform manner. You must assist with putting the timing system together and pulling it apart correctly without ripping out the cords or causing any other possible damage. The timing system is a very delicate and important piece of equipment in Flyball today so the correct use of this equipment is important. This includes unpacking and repacking the timing system in its container. The ANKC Supervisory Judge will be supervising you and assisting you at all times. You are required to fill out the official form provided. The official form must be signed off by the ANKC Supervisory Judge and the Controlling Body Representative on the day. All forms must be given to the Controlling Body Representative at the end of the competition, to be forwarded to the Controlling Body.

**Assisting with measuring of dogs: (this may be done at every provisional competition)**

All Judges should be supervised when measuring dogs' heights. No height card application forms can be sign by a Provisional Judge. The ANKC Supervisory Judge may sign off on the height if the dog has stood quietly by itself with out being held up by the handler and has stood in the correct stance as per the ANKC Rules.

A Provisional Judge should be shown the correct process for measuring a dog's height. They should also learn the correct stance for a dog who is about to be measured. The ANKC Supervisory Judge will be next to you for questions and guidance at all times.

You are required to fill out the official form provided. The official form must be signed off by the ANKC Supervisory Judge and the Controlling Body Representative on the day. All forms must be given to the Controlling Body Representative at the end of the competition, to be forwarded to the Controlling Body.

**Flyball Boxes and Balls: (this may be done at every provisional competition)**

You must learn how to correctly measure the boxes to see if they conform to ANKC Rules. They should be shown how to check balls to see if they comply with ANKC Rules (e.g. balls must bounce like a tennis ball). The ANKC Supervisory Judge will be instructing you and offer assistance if there are any questions and guidance at all times.

You are required to fill out the official form provided. The official form must be signed off by the ANKC Supervisory Judge and the Controlling Body Representative on the day. All forms must be given to the Controlling Body Representative at the end of the competition, to be forwarded to the Controlling Body.

**Only after completion of all the above items in Step 2 are Provisional Judges allowed to proceed to Step 3. Notification of approval to proceed will be sent in writing by the Controlling Body.**

**STEP 3 - Judging in the ring at non sanctioned competitions/demonstrations only where no points are awarded:**

Before a Provisional Judge enters the ring they will be informed by the ANKC Supervisory Judge how to handle any difficult situations when questioned by competitors on rulings. A Provisional Judge will not be judging in a low division or a division one race. They will be judging in a division two race to start with where mistakes are still made by the teams but not in every race.

An ANKC Supervisory Judge of good standing who has completed the provisional training themselves and judged at a minimum of 30 competitions will be appointed to stand beside them in the ring. You will be shown the correct process of checking the stewards and timekeepers are ready and how to start the race. The ANKC Supervisory Judge will stand beside/behind the Provisional Judge in the ring for a minimum of ten races or for their first competition. Then if you are still not sure of yourself the ANKC Supervisory Judge may continue to stand in the ring. The ANKC Supervisory Judge will then move to the back of the ring to watch for any problems that may arise. They will not leave the ring until the Provisional Judge has completed their Judging in the ring.

You are required to fill out the official form provided. The official form must be signed off by the ANKC Supervisory Judge and the Controlling Body Representative on the day. All forms must be given to the Controlling Body Representative at the end of the competition, to be forwarded to the Controlling Body.

To complete the required minimum of competitions a Provisional Judge will Judge at least 10 races at a minimum of 3 competitions during their provisional assignments. Totalling a minimum of 30 races before you can apply to be an approved ANKC Judge.

The ANKC Supervisory Judge will be at the back ring (or next to you) for questions and guidance at all times.

When you have submitted your application form you will be required by the Controlling Body to do a practical review under the ANKC Supervisory Judge at a sanctioned competition. The ANKC Supervisory Judge will then submit a written report to the Controlling Body.